

ALMA

Our selection

Per Alma Design il design non è un esercizio formale, ma una risposta concreta a chi vive lo spazio. Ogni prodotto nasce dall'ascolto e dall'attenzione ai bisogni reali: comfort, qualità, estetica e durabilità.

La progettazione integra cura delle proporzioni, attenzione al dettaglio tecnico, conoscenza dei materiali e processi produttivi consolidati. Il risultato sono arredi pensati per un utilizzo funzionale e duraturo, in cui l'estetica è sempre conseguenza di un progetto consapevole. Prima del prodotto, c'è l'esperienza di chi lo vive.

For Alma Design, design is not a formal exercise, but a concrete response to those who inhabit a space. Each product is born from listening and careful attention to real needs: comfort, quality, aesthetics, and durability.

The design process integrates a refined sense of proportion, attention to technical detail, knowledge of materials, and well-established manufacturing processes. The result is furniture conceived for functional and long-lasting use, where aesthetics are always the outcome of a conscious design approach. Before the product, there is the experience of those who live with it.

ALMA®

Indice interattivo

Collezioni / Collections

Sedie e poltroncine / Chairs and small armchairs

Amy	p. 196
Estrosa	p. 126
Jo Cuoiotto	p. 80
Jo	p. 86
Jo Soft	p. 88
Julie	p. 204
Lips	p. 62
Marlene	p. 160
Marnie	p. 92
Minnie	p. 12
Scala	p. 44, 52
Y Armchair	p. 120-122
X Chair	p. 114-119

Pouf e Sgabelli / Pouf and Stools

2525	p. 192
Anouk	p. 140
Estrosa	p. 126
Minnie	p. 28
Nonò	p. 186
Jo	p. 90
Pepper Soft	p. 178
Scala	p. 57
X Pouf	p. 109
X Stool	p. 125

Poltrone e divani / Armchairs and sofas

Amarcord	p. 132
Meg	p. 172
Scala	p. 34-43, 46-51
X Big	p. 109
X Big Too	p. 112
X Big Foot	p. 321

Tavolini / Coffee tables

Amarcord	p. 132
Magenta	p. 146
Malèna	p. 258
Mojito	p. 276
People	p. 280
Pepper	p. 182
Scala	p. 36-41, 46, 60
X Table	p. 111

Panche / Benches

X Beam	p. 316
--------	--------

Tavoli / Tables

Bistrò	p. 168
Clint	p. 70
Edward	p. 266
Grandangolo	p. 240
Ice Table	p. 286
Malèna	p. 258
Marnie	p. 99
Mojito	p. 276
Paloalto	p. 254
People	p. 280
Puntoquadro	p. 214
Rori	p. 228
Scala	p. 52-59
Set-up	p. 290
Virna	p. 270
Woodbridge	p. 248
X Table	p. 111

Tappeti / Rugs

Raja e Lana	p. 150-159
-------------	------------

About us

p. 4

Designer / Designers

p. 8

Schede prodotto / Product info

p. 295

Finiture / Finishes

p. 364

Rivestimenti/ Materials

p. 370

Alma

Il Total Living di Alma Design nasce da una visione progettuale in cui arredo e ambiente dialogano tra loro. Indoor e outdoor, residenziale e contract, diventano espressioni di un unico linguaggio, capace di adattarsi a contesti diversi. Questo approccio consente al progettista di costruire ambienti completi, caratterizzati da omogeneità formale, compatibilità materica e integrazione funzionale. Lo spazio diventa un ecosistema personalizzato e coerente, pensato per essere vissuto con naturalezza.

Le collezioni Total Living

Sedute, tavoli, imbottiti e complementi d'arredo sono pensati per offrire ad architetti, progettisti e interior designer una grande libertà compositiva senza rinunciare ad affidabilità e qualità tecnica. Ogni collezione interpreta il concetto di Total Living secondo un proprio linguaggio formale, mantenendo però una visione comune: prodotti pensati per integrarsi nello spazio, durare nel tempo e accompagnare l'esperienza quotidiana di chi li vive.

The Total Living concept by Alma Design stems from a design vision in which furniture and space engage in dialogue. Indoor and outdoor, residential and contract settings become expressions of a single language, capable of adapting to different contexts. This approach enables designers to create complete environments characterized by formal coherence, material compatibility, and functional integration. Space becomes a personalized and cohesive ecosystem, conceived to be experienced naturally.

The Total Living Collections

Chairs, tables, upholstered pieces, and furnishing accessories are designed to offer architects, planners, and interior designers broad compositional freedom without compromising on reliability and technical quality. Each collection interprets the concept of Total Living through its own formal language, while maintaining a shared vision: products created to integrate seamlessly into spaces, stand the test of time, and enhance the everyday experience of those who live with them.

About us

Da tre generazioni, Alma Design progetta e produce arredi capaci di coniugare estetica e funzionalità, eleganza e semplicità, tecnica ed emozione.

Alla guida dell'azienda ci sono Alessandra, Francesca e Lorenza, che hanno consolidato un percorso industriale fondato su competenze produttive, ricerca progettuale e tradizione manifatturiera Made in Italy.

Alma Design progetta in Franciacorta in collaborazione con i migliori designer del Made in Italy e produce nei principali distretti italiani dell'arredo, operando in ambito residenziale e contract a livello internazionale.

For three generations, Alma Design has been designing and manufacturing furniture that brings together aesthetics and functionality, elegance and simplicity, technique and emotion.

At the helm of the company are Alessandra, Francesca, and Lorenza, who have strengthened an industrial path rooted in manufacturing expertise, design research, and the Made in Italy production tradition.

Alma Design designs its collections in Franciacorta in collaboration with leading Italian designers, and manufactures in the main Italian furniture districts, operating internationally in both residential and contract sectors.



Alma

Alma Design si pone come partner di progetto per architetti, interior designer e progettisti che ricercano collezioni coerenti, affidabili dal punto di vista tecnico e riconoscibili per linguaggio formale.

L'azienda offre sistemi di arredo capaci di adattarsi a contesti diversi - residenziale, hospitality e contract -, mantenendo continuità stilistica e standard elevati. Designer, architetti e studi di progettazione trovano in Alma un interlocutore affidabile, capace di coniugare estetica e funzione, cultura del progetto e concretezza produttiva.

Alma Design positions itself as a project partner for architects, interior designers, and planners seeking collections that are coherent, technically reliable, and distinguished by a recognizable formal language.

The company offers furnishing systems capable of adapting to different contexts - residential, hospitality, and contract - while maintaining stylistic continuity and high standards. Designers, architects, and design studios find in Alma a reliable partner, able to combine aesthetics and function, design culture, and manufacturing expertise.



About us

La sostenibilità è parte integrante del nostro processo progettuale e produttivo.

Alma Design adotta un approccio basato sul controllo delle materie prime, sull'ottimizzazione dei processi e sulla progettazione di prodotti pensati per durare e facilitare il riciclo a fine vita.

Alcuni prodotti sono disponibili con pelle conciata esclusivamente con tannini vegetali, priva di metalli pesanti e agenti chimici, per ridurre l'impatto ambientale mantenendo elevate prestazioni di qualità e durata.

Sustainability is an integral part of our design and production process.

Alma Design adopts an approach based on careful control of raw materials, process optimization, and the design of products conceived to last and to facilitate recycling at the end of their life cycle.

Some products are available with leather tanned exclusively using vegetable tannins, free from heavy metals and chemical agents, in order to reduce environmental impact while maintaining high standards of quality and durability.



Azienda con sistema di gestione qualità certificato ISO 9001:2015. / Company with quality system ISO 9001:2015.

Designers

Alma

Daniele Lo Scalzo Moscheri

JF Smith

Marco Piva

Mario Mazzer

Nicola Cacco

Nicola Bonriposi

Mask Design Studio

Sergio Mori

Setacomincini

Stefano Soave

Tria.De design + Valèrie Galli

Valerio Sommella

I designer ci aiutano a dare forma alla nostra idea dell'abitare la casa, l'ufficio, gli spazi collettivi e quelli outdoor. Dalla loro interpretazione della personalità femminile, estroversa e sognatrice di Alma, che si esprime pienamente nei prodotti firmati dall'ufficio interno, nasce un catalogo ricco e vario, fatto di prodotti classici o all'avanguardia, sempre ispirati da un'instancabile curiosità.

The designers help us to shape our idea of living in the home, office, public spaces and outdoor ones. This rich and varied catalogue is born from their interpretation of Alma's feminine, extrovert and dreamer personality. A personality fully expressed in the products signed by the internal engineering dept, whose skills have brought Alma to present a collection made up of classic or avant-garde products, always inspired by tireless curiosity.

Collezioni
Collections

Minnie

Indoor

Minnie rivisita l'archetipo della sedia classica in chiave "bold", con un tocco giocoso e audace che catalizza l'attenzione a dispetto di un'apparente semplicità. Lo schienale abbondante - a mimare le orecchie di topolina - e le gambe rotondeggianti si ispirano al mondo del cartoon e trasmettono una sensazione di comfort e accoglienza.

Realizzata interamente in legno di frassino, Minnie è disponibile nella versione sedia con e senza braccioli, e sgabello.

Perfetta per contract, ristoranti, hotel, sale da tè e caffetterie, è una soluzione che ben si adatta anche agli spazi domestici che non vogliono passare inosservati.

Minnie revisits the archetype of classic chair in a "bold" key, with a playful and bold touch that catalyzes attention in spite of an apparent simplicity. The backrest abundant - to mimic the ears of little mouse - and rounded legs they are inspired by the world of cartoons and convey a feeling of softness and hospitality.

Made entirely of wood ash, Minnie is available in the version with and without armrests.

Perfect for contracts, restaurants, hotels, tea rooms and coffee shops, is one solution that is also perfectly suitable for domestic spaces they don't want go unnoticed.

Design
Mask Design Studio

Chair



Sedia Minnie, in frassino tinto salvia.
Minnie chair, in sage-stained ash wood.

Minnie è visibile anche a pag. 216, 218, 226, 227, 232 e 250.
Minnie visible also at p. 216, 218, 226, 227, 232 and 250.

Minnie

Sedia Minnie in frassino tinto salvia e tavolo Grandangolo con struttura verniciata bianca e piano in HPL bianco.

Minnie chair in sage-stained ash and Grandangolo table with white painted frame and white HPL top.

Chair



Minnie

Sotto / Below

Sedia Minnie, versione con accogliente bracciolo in frassino naturale.

Minnie chair, version with welcoming natural ash wood armrest.



A destra / On the right

Sedia Minnie in frassino naturale.

Minnie chair in natural ash wood.

Chair, armchair





A sinistra/ On the left

Sedia Minnie in frassino naturale con cuscino imbottito in ecopelle sabbia. Tavolo Rori con struttura in alluminio verniciato sabbia e piano in HPL color sabbia.
Tappeto Lana in colore nature.

*Minnie chair in natural ash wood with upholstered seat in sand-coloured faux leather.
Rori table with sand-painted aluminium frame and sand-coloured HPL top.
Lana rug in natural colour.*

Sotto / Below

Sedia Minnie in frassino naturale con cuscino imbottito in ecopelle sabbia.

Minnie chair in natural ash wood with upholstered seat in sand-coloured faux leather.





A sinistra/ On the left

Sedia Minnie in frassino naturale con cuscino imbottito in ecopelle sabbia.

Tavolo Puntoquadro finitura in rovere Asburgo naturale con fascia in frassino e guide in alluminio verniciate nero opaco.

Minnie chair in natural ash wood with upholstered seat in sand-coloured faux leather. Puntoquadro table natural Habsburg durmast oak finish with ash wood front band and matt black painted aluminium sliding guides.

Sotto / Below

Sedia Minnie, versione con accogliente bracciolo in frassino naturale.

Minnie chair, version with welcoming natural ash wood armrest.



Sedie Minnie, versione con accogliente
bracciolo in frassino tinto noce.
Tavolo Woodbridge in frassino tinto noce.
*Minnie chairs, version with welcoming
walnut-stained ash wood armrest.
Woodbridge table in walnut-stained ash wood.*



Minnie

Sotto / Below

Sedie Minnie, versione con accogliente bracciolo in frassino tinto noce.

Minnie chairs, version with welcoming walnut-stained ash wood armrest.

A destra / On the right

Sedie Minnie, versione con bracciolo in frassino tinto noce, ideale per l'appoggio al tavolo in ambienti contract.

Tavolo Marnie quattro gambe in frassino tinto noce e piano rettangolare in HPL bianco.

Minnie chairs, version with walnut-stained ash wood armrest, ideal for use as a table support in contract environments.

Marnie table four-leg version in walnut-stained ash-wood with rectangular in white HPL top.



Armchair



Sedia Minnie nella versione con accogliente bracciolo in frassino tinto nero con sedile imbottito in ecopelle Touch.

Tavolo Puntoquadro nella versione monocromatica frassino nero e guida verniciata nero, piano e gambe finitura nero.

Minnie chairs, version with welcoming black-stained ash wood armrest with upholstered seat in Touch ecoleather.

Puntoquadro extendable table in the monochromatic black ash wood version and black painted guide, top and legs in black finish.

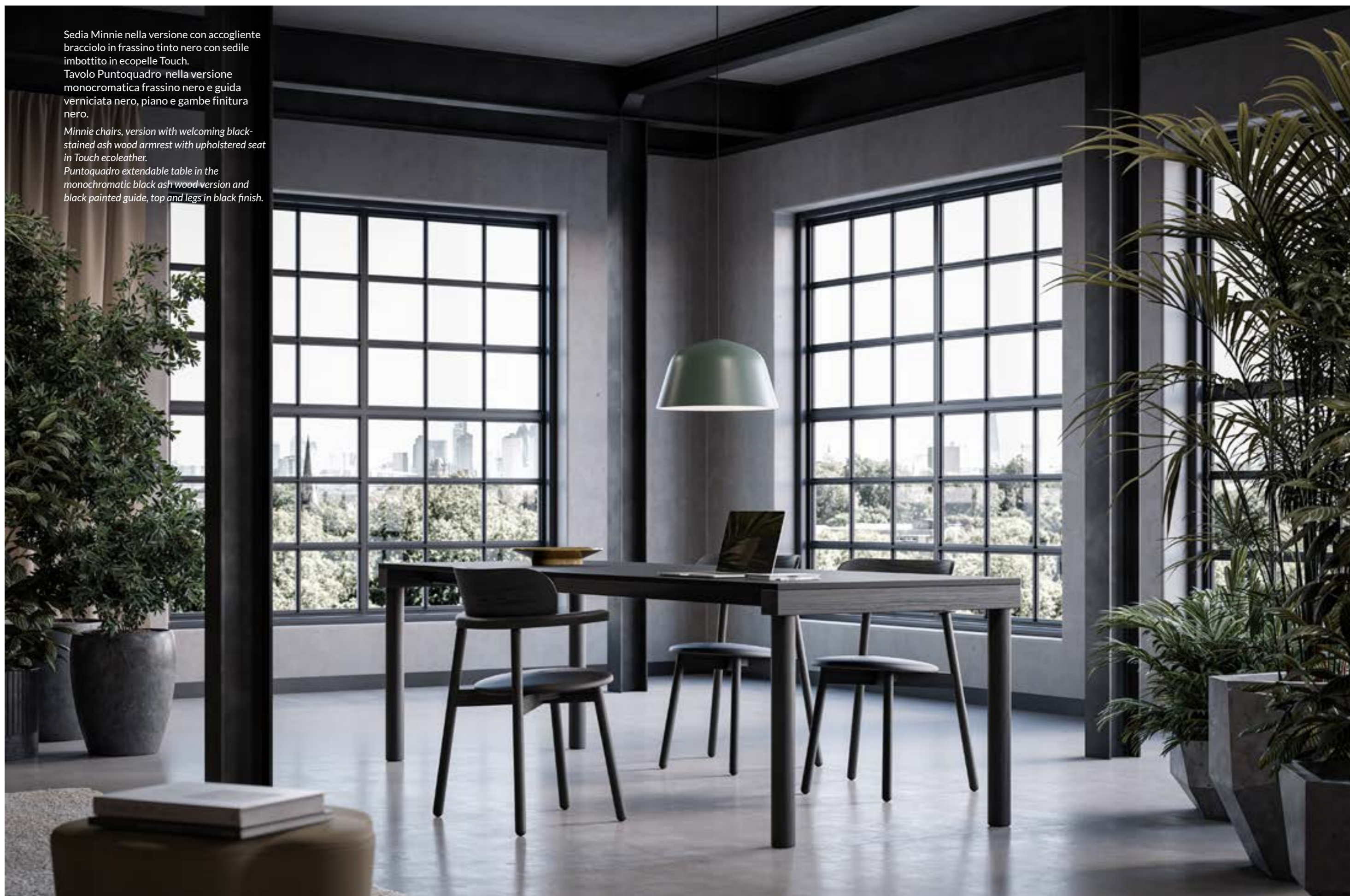



Sgabello Minnie in frassino naturale con sedile imbottito in tessuto Spalmato e poggiatesta in acciaio cromo satinato.

Minnie stool in natural ash with upholstered seat in Spalmato fabric and footrest in satin chrome steel.



Stool

A sinistra/ On the left

Sgabello Minnie in frassino naturale con sedile imbottito.

Minnie stool in natural ash with upholstered seat.

Sotto / Below

Sgabello Minnie in frassino naturale con sedile imbottito.

Minnie stool in natural ash with upholstered seat.



Minnie

Sotto / Below

Sgabello Minnie in frassino naturale.
Minnie stool in natural ash wood.

A destra / On the right

Sgabello Minnie in frassino naturale.
Tavolo Woodbridge altezza sgabello in
frassino naturale.
*Minnie stool in natural ash wood.
Woodbridge stool height version in natural
ash-wood.*



Stool



Scala

La collezione Scala è un tributo a Milano, città di cultura e di storia, capitale della moda e del design. La collezione è progettata per offrire un'esperienza di living completa e una sinergia inedita tra interno ed esterno. Linee sinuose che si fondono con l'ambiente circostante per coordinare indoor e outdoor che, oggi più che mai, si integrano e si compenetrano l'uno con l'altro dando origine a soluzioni ricercate e sofisticate in termini di stile, colore e materiali per soddisfare esigenze di arredo influenzate dal design e dalla moda. La struttura in metallo, che accomuna le proposte indoor e outdoor, restituisce leggerezza ed eleganza a tutti gli elementi. La collezione Scala Indoor è composta da poltrona, divano a due posti, coffee table, sedia, sgabello e tavolo fisso e allungabile. La collezione Scala Outdoor comprende poltroncina, poltrona, divano a due posti, coffee table e tavolo fisso.

The Scala collection is a tribute to Milan, a city of culture and history, capital of fashion and design. The collection is designed to offer a total living experience and an original synergy between indoor and outdoor. Soft lines that blend in with the surroundings to harmonize indoor and outdoor spaces that, now more than ever, interact and communicate with each other, creating a refined solution in terms of style, color and materials, inspired by haute couture and capable of meeting every design need. The metal structure, which brings the indoor and outdoor offerings together, conveys lightness and elegance to all the elements. The Scala Indoor Collection includes an armchair, a two-seat sofa, a coffee table, a chair, a stool, fixed and extendable table. The Scala Outdoor collection features chair, armchair, two-seat sofa, coffee table and fixed table.

Design
Studio Marco Piva

Indoor



Outdoor



Armchair



Divano Scala outdoor con struttura in acciaio verniciato bianco e intreccio in corda polipropilene sabbia. Cuscini divano in tessuto Tropea.

Scala outdoor sofa with white painted steel frame, polypropylene sand rope. Sofa cushions in Tropea fabric.

Divano e poltrone Scala outdoor con struttura in acciaio verniciato bianco e intreccio in corda polipropilene sabbia. Cuscini divano in tessuto Tropea, cuscini poltrone in tessuto Tropea. Tavolo coffee table con telaio verniciato bianco e piano HPL bianco.

Scala outdoor sofa and armchairs with white painted steel frame, polypropylene sand rope. Sofa cushions in Tropea fabric, armchairs cushions in Tropea fabric. Scala coffee table with white painted frame and white HPL top.



Divano e poltrona Scala outdoor con struttura in acciaio verniciato antracite e intreccio in corda polipropilene antracite, cuscini in tessuto Tropea. Tavolini con struttura in acciaio verniciato antracite, ovale in HPL color impero nero e tondo in HPL antracite.

Tappeto Raja in poliestere riciclato.

Scala outdoor sofa and armchair with anthracite painted steel structure and polypropylene anthracite rope, cushions in Tropea fabric.

Scala coffee tables with anthracite painted steel frame, oval HPL top in black imper color, round HPL top in anthracite color.

Raja rug in recycled polyester.





Divano e poltrona Scala outdoor con struttura in acciaio verniciato sabbia e intreccio in corda polipropilene sabbia, cuscini in tessuto Fortezza. Tavolino con struttura in acciaio verniciato sabbia piano tondo in HPL color sabbia.

Tappeto Raja in poliesterе riciclato.

Scala outdoor sofa and armchair with sand painted steel structure and polypropylene sand rope, cushions in Fortezza fabric. Scala coffee tables with sand painted steel frame, round HPL top sand color.

Raja rug in recycled polyester.

Divano e poltrone Scala outdoor con struttura in acciaio verniciato antracite e intreccio in corda polipropilene vinaccia. Cuscini divano in tessuto Tropea, cuscini poltrone in tessuto Tropea e Salina.

Scala outdoor sofa and armchairs with anthracite painted steel frame, polypropylene burgundy rope. Sofa cushions in Tropea fabric, armchairs cushions in Tropea and Salina fabric.



Scala



Chair

A sinistra/ On the left

Poltroncine Scala outdoor, con struttura in acciaio verniciato bianco intreccio in corda di polipropilene sabbia e cuscino con tessuto Fortezza; con struttura in acciaio verniciato antracite, intreccio in corda di polipropilene antracite e cuscino con tessuto Fortezza.

Scala outdoor small armchairs, with white painted steel frame sand polypropylene rope and cushions in Fortezza fabric; with anthracite painted steel frame, anthracite polypropylene rope and cushions in Fortezza fabric.

Sotto / Below

Poltroncina Scala outdoor con struttura in acciaio verniciato antracite, intreccio in corda di polipropilene antracite, sedile e schienale imbottiti con tessuto Fortezza.

Scala outdoor armchair with anthracite painted steel frame, anthracite polypropylene rope and Fortezza cushion, for seat and back.



Poltrona e divano Scala con struttura in acciaio verniciato nero rivestiti in tessuto Jojo; tavolino ovale con struttura in acciaio verniciato nero e piano HPL color impero nero. Tappeto Raja, con intreccio in poliestere riciclato.

Scala armchair and sofa with black painted steel frame, upholstered in Jojo fabric; oval coffee table, black painted steel frame and HPL top matt lava colour. Raja rug, in recycled polyester





A sinistra/ On the left
Poltrona Scala con struttura
in acciaio verniciato bronzo rivestita in
ecopelle Touch.
*Scala armchair with bronze painted
steel frame, upholstered in ecoleather Touch.*

Sotto / Below
Poltrona Scala con struttura in acciaio
verniciato nero rivestita in tessuto Jojo.
Tappeto Raja, poliestere riciclato.
*Scala armchair with black painted
steel frame, upholstered in Jojo fabric.
Raja rug, in recycled polyester.*



Scala

Divani Scala con struttura in acciaio verniciato bronzo e rivestimento Stone Velvet e velluto Luna.

Tappeto Lana, bouclè misto lana e viscosa.

Scala sofas with steel painted bronze frame, upholstered in Stone Velvet and velluto Luna. Lana rug, bouclè in wool and viscose.



Sofa



Tavolo Scala allungabile con struttura in acciaio verniciato bronzo, piano in HPL Ø1200 mm calacatta. Sedia Scala con telaio in acciaio verniciato bronzo e imbottita in Stone Velvet.

Scala extendable table with bronze-painted steel frame and HPL top Ø1200 mm Calacatta. Scala chair with bronze-painted steel frame and upholstered in Stone Velvet fabric.



Scala



Chair, table

A sinistra/ On the left

Sedie Scala con struttura in acciaio verniciato bronzo rivestite in ecopelle Touch.

Scala chairs with bronze painted steel frame upholstered with Touch ecoleather.

Sotto / Below

Tavolo allungabile Scala con struttura in acciaio verniciato bronzo, meccanismo in alluminio verniciato nero, piano in HPL Ø1200 mm brown lucido, prolunga centrale in laminato nero da 400 mm.

Scala extendable table with bronze painted steel frame, black painted aluminium mechanism, HPL top Ø1200 mm shiny brown colour, central extension in black laminate 400 mm.



Scala

Sotto / Below

Tavolo Scala allungabile con struttura in acciaio verniciato bronzo, piano in HPL calacatta. Sedia Scala con telaio in acciaio verniciato bronzo e imbottita in Stone Velvet.

Scala extendable table with bronze-painted steel frame and Calacatta HPL top. Scala chair with bronze-painted steel frame upholstered in Stone Velvet fabric.



56

A destra / On the right

Sgabelli Scala con struttura in acciaio verniciato bronzo rivestiti con Stone Velvet.

Scala stools with bronze painted steel structure upholstered with Stone Velvet.

Stool, chair, table



57

Scala

Tavoli Scala con struttura in acciaio verniciato bronzo: allungabile con piano in HPL brown lucido e prolunga in laminato nero; fisso con piano da 2000x1000 mm in HPL color Impero Nero opaco.

Scala tables with bronze painted steel frame: extendable with HPL shiny brown and extensions in black laminate; fix top version with 2000x1000 mm HPL top matt Black Imper color.

Coffee table



Tavolini Scala con struttura in acciaio verniciato bronzo e piano in MDF laccato bianco; con struttura in acciaio verniciato nero e piano in MDF laccato bianco; con struttura in acciaio verniciato bronzo e piano in MDF laccato rosso ossido.

Scala coffee tables with bronze painted steel structure and white lacquered MDF top; with structure in black painted steel and white lacquered MDF top; with structure in bronze painted steel and red oxyde lacquered MDF top.



Lips



Indoor

Dalla combinazione di due elementi curvi, avvolgenti come un guscio, nasce la poltroncina Lips. Una solida struttura in legno curvato accoglie l'imbottitura, rivestita in un'ampia gamma di tessuti, pelli ed ecopelli. Confortevole come una poltroncina, Lips è versatile come una sedia: con gambe in legno, si adatta infatti a qualsiasi contesto – salotto domestico, camera di hotel o sala di un ristorante.

Lips armchair is born from the combination of two curved elements, enveloping like a shell. A solid wood frame in bent wood hosts the upholstery, covered by a wide range of fabrics, faux leather as well as real leather. Extremely comfortable, Lips is as versatile as a chair: with wooden legs, it fits to manifold locations – living rooms, hotel rooms and restaurant halls, too.

Design
Studio Mario Mazzer

Armchair



Poltrona Lips con gambe e seduta in frassino tinto noce e rivestimento in tessuto Jojo.

Lips armchair with legs and seat in walnut-stained ash wood and Jojo fabric upholstery.

Poltrone Lips con gambe e seduta in frassino tinto noce e rivestimento in tessuto Jojo. Tavolo Rori struttura in alluminio verniciate bianco e piano in laminato bianco.

Lips armchairs with legs and seat in walnut-stained ash and Jojo fabric upholstery. Rori table with white-painted aluminium structure and white laminate top.



Poltrone Lips con gambe e seduta in frassino color noce e rivestimento in tessuto Spalmato. Tavolo Clint con struttura in acciaio calamina e piano in multistrato di frassino color noce.

Lips armchairs with legs and seat walnut stained ashwood and Spalmato fabric upholstery. Clint table with calamine steel structure and walnut ash-wood multilayer top.





Armchair

A sinistra/ On the left

Poltrona Lips con gambe e seduta in frassino tinto nero e rivestimento in velluto Stone Velvet; con gambe e seduta in frassino naturale e rivestimento in tessuto Jojo.

Lips armchair with legs and seat in black painted ash-wood and Stone Velvet upholstery; with legs and seat in natural ash-wood and Jojo fabric upholstery.

Sotto / Below

Poltrona Lips con gambe e seduta in frassino naturale e rivestimento in tessuto Jojo.

Lips armchair with seat and back in natural ash-wood, upholstered with Jojo fabric.



Clint



Indoor

Ispirato alla cultura e all'estetica orientali, il tavolo Clint ricorda nella struttura un grande origami d'acciaio. Un volume forte e geometrico, bilanciato dalla presenza del piano in legno. Scultoreo e moderno, il tavolo Clint è disponibile in varie dimensioni, finiture e nella versione allungabile.

Inspired by Oriental culture and aesthetic, Clint frame recalls a big origami made of steel. Its strong and geometrical shape is balanced by the presence of the wooden top. Sculptural and modern, Clint is available in various sizes, finishes and in the extendable version.

Design
Studio Mario Mazzer

Table



Tavolo Clint, versione fissa, con struttura verniciata bianca e piano in laminato bianco cemento.

Clint table, fixed version, with white painted structure and white cement laminate top.

Clint

Tavolo Clint versione allungabile con struttura in acciaio verniciato bianco, piano in laminato bianco cemento e meccanismo allungabile in alluminio. Poltroncine Lips con scocca rivestita in pelle.

Clint extendable table with structure in white painted steel white laminate top with cement finish and extendable aluminium mechanism. Lips armchairs with leather upholstered seats.

Table



Tavolo Clint con struttura in acciaio
calamina e piano laminato tinta noce con
meccanismo allungabile in alluminio.
Tappeto Lana, misto lana e viscosa.

*Clint extendable table with structure in
calamine steel and top in walnut laminated.
Lana rug, bouclé in wool and viscose.*



Clint

Tavolo Clint versione fissa, con struttura Calamina e top in HPL nero.

Clint table, fixed version, with structure in calamine steel and top in black HPL.



Table

Tavolo Clint con struttura in acciaio verniciato nero e piano in frassino tinto nero.

Clint table with black painted steel frame and black stained ash top.



Clint

Tavolo Clint, versione fissa, con struttura calamina e piano in HPL nero.
Poltrone Jo Cuoiotto.

*Clint table, fixed version, with structure in calamine steel and top in black HPL.
Jo Cuoiotto armchairs.*

Table



Jo Cuoietto



Indoor

Morbida e accogliente, la poltroncina Jo Cuoietto ha un design giocoso dovuto alla particolare bombatura delle gambe e dell'elemento schienale. La sua particolare lavorazione in cuoio, ideale negli spazi indoor sia di luoghi collettivi sia di spazi residenziali, rappresenta la massima espressione dell'artigianalità italiana.

Soft and comfortable, Jo Cuoietto armchair has a fancy design due to its particular legs and backrest crowning. Covered in hard leather, ideal for indoor spaces in both for public and private places, is the best example of our italian handcraft ability.

Design
Studio Mario Mazzer

Chair



Poltroncina Jo rivestita in cuoietto color testa di moro.
Jo small armchair in hard leather brown.

Jo Cuoietto



Desingner
Lorem Ipsum

Chair

A sinistra / On the left

Poltroncina Jo rivestita in cuoietto color biscotto.
Tavolo Rori verniciato antracite con piano in HPL nero.
Tappeto Lana Bouclè misto lana e viscosa.

Jo small armchair in hard leather biscuit. Rori table painted anthracite with black HPL top. Lana rug Bouclè in wool and viscose.

Sotto / Below

Poltroncina Jo rivestimento in cuoietto color biscotto.

Jo armchair with biscuit-coloured leather upholstery.



Jo Cuoietto

Sotto / Below

Poltroncina Jo rivestimento in cuoietto color Testa di Moro.

Jo armchair with brown-coloured leather upholstery.

A destra / On the right

Poltroncina Jo rivestita in cuoietto biscotto e burgundi.

Jo small armchair in hard leather biscuit and burgundy.



Morbida e accogliente, la poltroncina Jo ha un design giocoso dovuto alla particolare bombatura delle gambe e dell'elemento schienale. La versione in polietilene, declinata anche nel formato dello sgabello, stampata in rotomoulding, è ideale negli spazi indoor e outdoor sia di luoghi collettivi sia di spazi residenziali. La versione Jo soft è ideale per arredare spazi interni, offrendo un livello di comfort superiore grazie all'imbottitura dello schienale e del sedile.

Soft and comfortable, Jo armchair has a fancy design due to its particular legs and backrest crowning. The polyethylene version, also available in stool version, injected in rotomoulding, is ideal for indoors and outdoors, both for public and private places. The Soft version is ideal for indoor spaces, offering enhanced comfort thanks to the backrest and seat upholstery.

Design
Studio Mario Mazzer



Poltroncine Jo in polietilene giallo ambra e in polietilene verde bosco.

Jo small armchairs in yellow amber polyethylene and in dark green polyethylene.

Poltroncina Jo soft in polietilene antracite,
sedile e schienale in ecopelle Touch.
Tavolo Paloalto in acciaio verniciato antracite
e piano in frassino nero.

*Jo soft small armchair in anthracite
polyethylene, seat and back upholstered in
Touch ecoleather.*

*Paloalto table steel anthracite painted frame
and top in black ash-wood.*



Jo

Sgabelli Jo in polietilene bianco. Tavolo Mojito alto in alluminio verniciato bianco, piano tondo in HPL bianco.

Jo stools in white polyethylene. Mojito table in white painted aluminium and HPL round top.

Stool

Marnie



Indoor

Marnie è una collezione di sedie e tavoli che si contraddistingue per la struttura in frassino che coniuga la solidità del legno alla leggerezza. Merito della particolare lavorazione di sciancratura dei masselli, che rende braccioli e schienali delle sedie e gambe dei tavoli affusolati e dunque visivamente più sottili, come arbusti di un bosco. La sedia, che ha il sedile imbottito, è disponibile anche con schienale imbottito; il tavolo con piano tondo, rettangolare o quadrato, sempre con angoli stondati.

Marnie is a unique collection of chairs and tables with a frame in ashwood, so as to be strong and light at the same time. Armrests and backrests, as well as table legs, are processed by lumps sidecut, so as to result as thin as bushes of a wood. The chair has an upholstered seat, and is also available with an upholstered backrest; the table is available with circular, rectangular, or squared top, always with rounded angles.

Design
Studio Daniele Lo Scalzo Moscheri

Chair



Sedia Marnie in frassino tinto nero con sedile in tessuto Jojo.
Marnie chairs black-stained ash with Jojo fabric.



Sedie Marnie in frassino tinto nero con sedile e schienale imbottiti in tessuto Jojo. Tavolo Marnie in frassino tinto nero e top in HPL nero.

Marnie chairs in black painted ash-wood with seat and back upholstered in Jojo fabric. Marnie table in black-stained ash with black HPL top.

Marnie

Sotto / Below

Sedia Marnie in frassino tinto noce con sedile e schienale imbottiti in tessuto Jojo.

Marnie chair in walnut painted ash-wood with seat and back upholstered in Jojo fabric.

A destra / On the right

Sedie Marnie in frassino naturale con sedile in tessuto Plush; in frassino tinto noce con sedile in tessuto Plush; in frassino tinto nero con sedile e schienale imbottiti in tessuto Plush.

Marnie chairs in natural ash-wood with Plush fabric; in walnut-painted ash-wood with Plush fabric seat; in black painted ash-wood with seat and back upholstered in Plush fabric.



Chair



Tavolo Marnie tre gambe in frassino naturale con piano tondo in MDF laccato bianco.
Sedie Marnie in frassino naturale con sedile e schienale imbottiti in tessuto Jojo.
Tappeto Lana, bouclè misto lana e viscosa.

*Three-leg Marnie table in natural ash-wood with round top in MDF white laquered. Marnie chairs in natural ash-wood with seat and back upholstered in Jojo fabric.
Lana rug, bouclè in wool and viscose.*



Tavoli Marnie in frassino tinto con piani in
MDF laccati.
Marnie tables in ash-wood with MDF tops.





Tavolo Marnie in frassino naturale con piano rettangolare in HPL bianco. Sedie Amy in polipropilene bianco con cuscino sedile in ecopelle.

Marnie table in natural ash-wood with rectangular in white HPL top. Amy chairs white polypropylene with ecoleather seat cushion.

Tavolo Marnie in frassino tinto noce con piano in HPL brown lucido.

Sedie Minnie, versione con accogliente bracciolo in frassino tinto noce.

Tappeto Lana, bouclè misto lana e viscosa.

Marnie table in walnut-painted ash-wood with rectangular top in HPL shiny brown.

Minnie chairs, version with welcoming walnut-stained ash wood armrest.

Lana rug, bouclè in wool and viscose.



Marnie

Tavolo Marnie quattro gambe in frassino tinto noce con piano rettangolare in HPL impero nero.

Marnie table four-leg version in walnut-painted ash-wood with rectangular top in HPL black imper.



X Collection

Indoor
Outdoor

X è una collezione ampia e multiforme, in continua evoluzione. Disegnata da Mario Mazzer a partire da un segno a forma di X che ricorre nel design, si distingue per la qualità dei materiali. La collezione comprende la poltroncina Y, dalle linee morbide e raccolte, e la poltrona X Big, entrambe con base in legno o acciaio per l'uso domestico e contract oppure girevole a razze per l'ufficio; il divano due o tre posti; la sedia X chair e lo sgabello X stool; tavoli e tavolini di diverse altezze con struttura in legno o acciaio e piano laccato oppure interamente in legno.

X is a wide and various collection in continuous evolution. Designed by Mario Mazzer starting from the simple X sign - that often recurs in the collection - X stands out for its materials quality. This collection comprehends the Y chair with soft and simple lines, and the X Big armchair; both with a wooden or steel base for private and contract places, it is also available in the swivel version with legs suitable for the office world; the X collection also includes a two - or three - seat sofa; X chair and X stool; tables and service tables of various heights, with wooden or steel frame and laquered top or entirely in wood.

Design
Studio Mario Mazzer

Armchair, coffee table, pouf



Poltrona X 2 Big con base in frassino naturale, seduta e poggiatesta in tessuto Plush con comoda maniglia in cuoio per facilitare il movimento. X Pouf con base in frassino naturale e seduta in tessuto Plush. Tavolino X Table con struttura in frassino naturale e piano in MDF laccato bianco.

X 2 Big armchair with base in natural ash-wood, unholstered in Plush fabric with convenient hard leather handle to facilitate seat handling.

X Pouf with base in natural ash-wood and seat in Plush fabric. X Table coffee table with structure in natural ash-wood, top in white lacquered MDF.



Armchair, table, coffee table

A sinistra / On the left

Poltrona X 2 Big con poggiatesta con base in acciaio verniciato bianco e seduta in tessuto Jojo. Poltrona X Big con base girevole quattro razze in alluminio e seduta bicolore in tessuto Jojo.

X 2 Big armchair with headrest with steel base and seat in Jojo fabric. X Big armchair with four-leg swivel base in aluminium and bicolor seat in Jojo fabric.

Sotto / Below

X Table con struttura in frassino naturale e piano in MDF laccato bianco; con struttura in metallo verniciato antracite e piano in laminato antracite; con struttura e piano in frassino tinto nero.

X Table with structure in natural ash-wood and white lacquered MDF top; with anthracite painted steel structure and anthracite laminate top; with structure and top in black stained ash-wood.



X Collection



Armchair, coffee table, sofa

Poltrona X Big con base in frassino tinto nero e seduta in tessuto Plush. Tavolino X Table con struttura e piano in frassino tinto nero. Divano X Big Too a due posti con struttura in frassino tinto nero e seduta in tessuto Plush.

X Big armchair with base in black-stained ash-wood and seat in Plush fabric. X coffee table with structure and top in black stained ash-wood. X Big Too two-seat sofa with black stained ash structure and Plush fabric seat.



X Collection



114

Chair

A sinistra / On the left

Sedia X wood con struttura in frassino naturale e scocca in polipropilene color sabbia, croce in frassino naturale.
Tappeto Lana, misto lana e viscosa.

X wood chair with ash-wood natural base and polypropylene shell sand colour, cross in natural ash-wood.

Lana rug, bouclè in wool and viscose.

Sotto / Below

Profilo scocca in polipropilene antracite su struttura in frassino noce.

Silhouette of the polypropylene anthracite shell on the walnut ash-wood base.



115

X Collection

Sotto / Below

Particolare della croce in frassino noce sul sedile.

Detail of the ash-wood walnut cross on the seat.

A destra / On the right

Sedia X wood con struttura in frassino noce e scocca in polipropilene color antracite, croce in frassino noce; sedia X spider con struttura in metallo sezione rettangolare verniciata antracite, scocca e croce in polipropilene antracite.

X wood chair with ash-wood natural base and polypropylene shell sand colour, cross in natural ash-wood; X spider chair with rectangular tube base, anthracite painted, shell and cross in polypropylene anthracite colour.



Chair





Chair

A sinistra / On the left

Sedia X wood con struttura in frassino
noce, scocca in polipropilene color bianco e
cuscino imbottito in tessuto Jojo.

*X wood chair with ash-wood natural
base, polypropylene shell white colour and
upholstered cushion in Jojo fabric.*

Sotto / Below

Sedia X wood, dettaglio cuscino.
X wood chair cushion detail.



Poltroncine Y con base girevole quattro razze in alluminio e seduta in lana cotta Hero; con gambe in frassino naturale e seduta in lana cotta Hero; con gambe in metallo a sezione rettangolare verniciato antracite e seduta in lana cotta Hero; con base cinque razze verniciato nero opaco con ruote e seduta in lana cotta Hero.

Y Armchair with four-star swivel base in aluminum and seat in Hero boiled wool; with legs in natural ash-wood and seat in Hero boiled wool; with legs in anthracite painted rectangular steel tube and seat in Hero boiled wool; with five-star aluminum base with wheels and seat in Hero boiled wool.



X Collection

Sotto / Below

Poltroncina Y wood, dettaglio cuscino.
Y wood armchair cushion detail.



A destra / On the right

Poltroncina Y wood con struttura in frassino tinto nero e scocca in polietilene color verde bosco e cuscino imbottito in tessuto Roccia.
Tavolo Rori con struttura verniciata antracite e piano in HPL color antracite.

Y wood armchair with black-stained ash frame, forest green polypropylene shell and upholstered cushion in Roccia fabric. Rori table with anthracite-painted frame and anthracite-coloured HPL top

Armchair



X Collection

Poltroncine Y con gambe in metallo conico verniciato sabbia e seduta in tessuto Roccia. Tavolo X Table con struttura in acciaio verniciato sabbia e piano in laminato bianco, Y Armchair with sand painted conical metal legs and Roccia fabric seat. X Table with sand painted steel structure and white laminated top.



Armchair, stool

Sgabello X wood con struttura in frassino naturale e scocca in polipropilene color bianco, croce in frassino naturale; sgabello X spider con struttura in metallo sezione rettangolare verniciata sabbia, scocca e croce in polipropilene sabbia.

X wood stool with ash-wood natural base and polypropylene shell white colour, cross in natural ash-wood; X spider stool with rectangular tube base, sand painted, shell and cross in polypropylene sand colour.



Estrosa

Indoor
Outdoor

Primo prodotto firmato Alma nel 2008, Estrosa ne rappresenta da allora una sorta di manifesto. Realizzata in estruso di alluminio anodizzato, unisce un design essenziale a una trasversalità che la rende adatta a qualsiasi contesto. Benché ispirato al processo produttivo di estrusione, il nome allude anche all'originalità "estrosa" del profilo di sedile e schienale.

First product designed by Alma in 2008, since then Estrosa represents a sort of symbol. Made of extruded anodised aluminium, it combines an essential design with a transversality that makes it suitable for any context. Even if inspired by the extrusion production process, its name also recalls the fancy originality of the seat and backrest profile.

Design
Studio Setacomincini

Chair, stool

Sedia e sgabello Estrosa con telaio a slitta in acciaio verniciato nero, sedile e schienale in alluminio anodizzato nero.

Estrosa chair and stool with cantilever frame in black painted steel, seat and back in black anodized aluminum.



Estrosa è visibile anche a pag. 224 e 268. / Estrosa visible also at p. 224 and 268.

Sedie Estrosa con telaio a 4 gambe in acciaio verniciato alluminio, sedile e schienale in alluminio anodizzato colore grigio.
Tavoli People con base in acciaio verniciato bianco e piano quadrato in nobilitato bianco.

Estrosa chairs with 4-leg frame in aluminum painted steel, seat and back in anodized aluminum grey color.
People tables with base in white painted steel and square top in white melamine.



Estrosa

Schienale sedia Estrosa in estruso di alluminio anodizzato nero.

Estrosa back of the chair, extruded aluminium with black anodization.



130

Chair

Sedia Estrosa con telaio a 4 gambe in acciaio verniciato nero, sedile e schienale in alluminio anodizzato colore nero.

Tavolo Edward con struttura in acciaio verniciato nero e piano in nobilitato nero.

Estrosa chairs with 4-legs frame in black painted steel, seat and back in anodized aluminium black color. Edward table with base in black painted steel and top in black melamine.



131

Amarcord

Indoor

La collezione Amarcord è un omaggio al modernismo. La poltrona ha un design semplice ed essenziale: la seduta, ampia e confortevole, la rende ideale come lounge per sale d'attesa o zone relax. La scocca è disponibile completamente imbottita o in rovere con cuscino imbottito, mentre la base è a slitta in acciaio cromato o verniciato. La poltrona si accompagna ai tavoli della collezione.

Amarcord collection is a tribute to modernism. The armchair has a simple and essential design: the seat, wide and comfortable, makes it suitable as lounge for waiting rooms and relax areas. The seat is available completely upholstered or in oak-wood with a padded pillow, while the cantilever base is in chromed or painted steel. The armchair completes the family with its coffee tables.

Design
Studio Nicola Cacco

Armchair, coffee table

Poltrona lounge Amarcord con telaio a slitta in acciaio verniciato bianco e scocca rivestita in tessuto King L Kat. Tavolino Amarcord con base in acciaio verniciato bianco e piano in MDF laccato bianco.

Amarcord lounge chair with white painted steel cantilever frame and shell upholstered in King L Kat fabric.

Amarcord coffee table with white painted steel base and white lacquered MDF top.



Poltrone lounge Amarcord con telaio a slitta in acciaio cromato, scocca in rovere con cuscino o completamente rivestite in lana cotta Hero.

Tavolini Amarcord con base in acciaio cromato e piano in MDF laccato nero.

Amarcord lounge armchairs with cantilever frame in chromed steel and oak-wood shell with cushion or completed upholstered in Hero boiled wool.

Amarcord coffee tables with chromed steel base and top in black lacquered MDF.



Amarcord



136

Armchair

Poltrona lounge Amarcord con telaio a slitta in acciaio verniciato nero, scocca in rovere con cuscino rivestito in lana cotta Hero.

Amarcord lounge armchair with cantilever frame in black painted steel and oak-wood shell with cushion upholstered in Hero boiled wool.



137

Amarcord

Sotto / Below

Tavolino Amarcord H256 mm con base in acciaio e piano in MDF laccato bianco.

Amarcord coffee table H256 mm with steel base and white lacquered MDF top.

A destra / On the right

Tavolino Amarcord con base in acciaio verniciato bianco e piano in MDF laccato bianco.

Amarcord coffee table with white painted steel base and white lacquered MDF top.



Coffee table



Anouk

Anouk è uno sgabello essenziale che unisce alla base in metallo cromato una seduta che evoca una piccola onda. Si personalizza scegliendo tra sedile in legno multistrato, sedile completamente imbottito o sedile imbottito con legno a vista.

Anouk is an essential stool matching the chromed metal base with a seat recalling a little wave. It can be personalized by choosing between the multilayer wooden seat, the completely padded seat, or a padded seat with visible wood.

Design
Studio Nicola Cacco

Stool

Sgabelli Anouk in acciaio cromato con scocca in legno multistrato wengè e scocca in legno multistrato rovere.
Anouk stools in chromed steel with shell in wengè plywood and with seat in oak plywood.



Anouk è visibile anche a pag. 285. / Anouk visible also at p. 285.

Anouk

Sgabelli Anouk in acciaio verniciato nero e
scocca rivestita in ecopelle Touch.
Tavolo People alto in acciaio verniciato nero
con piano nero.

*Anouk stools in painted black steel with
upholstered seat in Touch ecoleather. People
table high version black painted steel and top in
black color.*

Stool

Anouk



144

A sinistra/ On the left

Sgabello Anouk con struttura in acciaio verniciato nero, scocca in multistrato rovere con cuscino in ecopelle Touch.

Anouk stool in painted black steel structure, shell in oak plywood and cushion in Touch ecoleather.

Sotto / Below

Dettaglio seduta sgabello Anouk con cuscino in ecopelle Touch.

Detail Anouk stool with cushion in Touch ecoleather.



145

Magenta

Indoor

Magenta è un colore, ma è soprattutto una delle vie storiche di Milano, ancora oggi tra le più caratteristiche. E proprio le atmosfere eleganti e ricercate delle residenze milanesi del centro hanno ispirato i tavolini della collezione Magenta, realizzata con materiali che richiamano gli anni Cinquanta e rappresentano un omaggio alla stagione d'oro del design italiano.

Magenta is a colour, but also one of the most ancient and characteristic streets in Milan. Exactly those elegant and prestigious features of the buildings in the city-centre have inspired for the Magenta collection tables, made with materials that recall the 50's and represent a tribute to the golden season of the Italian design.

Design
Studio Marco Piva

Coffee table

Tavolini Magenta con struttura in metallo verniciato nero e piano in marmo nero marquina e con struttura in metallo verniciato nero e piano in marmo Carrara lucido.

Magenta coffee tables with structure in black painted metal and top in black marquina marble with structure in black painted metal and top in glossy Carrara marble.





A sinistra/ On the left

Tavolino Magenta H 520 mm con piano tondo Ø500 mm in marmo nero marquina con particolare lavorazione del bordo.

Magenta coffee table H 520 mm with black marquina marble top, Ø500 mm, edge detail.

Sotto / Below

Tavolini Magenta con struttura in metallo verniciato nero e piano in marmo Carrara lucido.

Magenta coffee tables with structure in black painted metal and top in glossy Carrara marble.



Ad arricchire la proposta total living di Alma la nuova collezione di tappeti per indoor e outdoor. I modelli Lana da interno sono interamente annodati a mano con effetto bouclé a nodi in rilievo. Tappeti morbidi e a nodi fissi altamente resistenti all'usura, composti al 40% da lana e al 60% da viscosa che gli conferisce un effetto luminoso.

In un'ottica ecosostenibile i tappeti Raja da esterno sono realizzati completamente in poliestere riciclato, una fibra tessile sintetica che si ottiene fondendo la plastica e rifilandola in una nuova fibra di poliestere, che consente di dare una seconda vita a dei materiali non biodegradabili.

The new collection of indoor and outdoor rugs enriches Alma's Total Living offerings.

Lana indoor rugs are entirely hand-knotted with a raised knot bouclé effect. Soft, fixed-knot, and highly wear-resistant rugs, composed of 40% wool and 60% viscose, which gives them a shiny finish.

Environmentally conscious, Raja outdoor rugs are entirely made by recycled polyester, a synthetic textile fiber obtained by re-melting plastic into a new polyester fiber, giving non-biodegradable materials a second life.

Design
Studio Alma



Tappeto Raja in melange nature.
Raja rug nature melange.

Tappeto Raja, con intreccio in poliestere riciclato; Poltrona e divano Scala con struttura in acciaio verniciato nero rivestiti in tessuto Jojo; tavolino ovale con struttura in acciaio verniciato nero e piano HPL color impero nero.

Raja rug, in recycled polyester; Scala armchair and sofa with black painted steel frame, upholstered in Jojo fabric; oval coffee table, black painted steel frame and HPL top matt lava colour.



Tappeto Lana, bouclè misto lana e viscosa.
Tavolo Marnie tre gambe in frassino naturale
con piano tondo in MDF laccato bianco.
Sedie Marnie in frassino naturale con sedile
e schienale imbottiti in tessuto Jojo.

*Lana rug, bouclè in wool and viscose.
Three-leg Marnie table in natural ash-wood
with round top in MDF white laquered. Marnie
chairs in natural ash-wood with seat and back
upholstered in Jojo fabric.*



Tappeto Lana, misto lana e viscosa. Tavolo Clint con struttura in acciaio calamina e piano laminato tinta noce con meccanismo allungabile in alluminio.

*Lana rug, bouclé in wool and viscose.
Clint extendable table with structure in calamine steel and top in walnut laminated.*



Raja, Lana



158

Rugs

A sinistra/ On the left

Tappeto Raja con intreccio in poliestere riciclato.

Divano Scala con struttura in acciaio verniciato bianco e intreccio in corda poliestere sabbia, cuscini in tessuto Tropea.

Raja rug in recycled polyester.

Scala sofa with white painted steel structure and polyester sand rope, cushions in Tropea fabric.

Sotto / Below

Tappeto Raja in melange blu e tappeto Lana color nature.

Raja rug melange blu and Lana rug in nature colour.



159

Marlene

Indoor
Outdoor

La classica sedia in legno rinasce in versione contemporanea. Marlene riprende le linee delle sedie da bistrot, ma le reinterpreta grazie al policarbonato brillante e al nylon lucido, due materiali che riverberano la luce. Realizzata con tecnologia air moulding, Marlene è resistente ai raggi UV e perfettamente impilabile, motivo per cui è particolarmente adatta all'interno e all'esterno di bar e ristoranti, oltre che negli ambienti domestici.

The classic wood chair is born again in a contemporary version. Marlene resumes lines from bistrot, but it reinterprets them thanks to bright polycarbonate and polished nylon, both materials do spread light. Produced by air moulding technology, Marlene is UV-resistant and stackable, this is the reason why it is particularly suitable for interior and exterior spaces of cafés and restaurants, as well as for home places.

Design
Studio JF Smith

Chair

Sedia Marlene in nylon bianco lucido e in policarbonato trasparente.
Marlene chair, in shiny white nylon and transparent polycarbonate.



Sedie Marlene in nylon nero lucido;
in policarbonato fumé; in policarbonato rosso.
*Marlene chairs in black polished nylon;
fumé polycarbonate; in red polycarbonate.*



Sedie Marlene in nylon nero lucido. Tavolo Grandangolo con struttura in alluminio verniciato antracite e piano in nobilitato.

Marlene chairs in shiny black nylon. Grandangolo table with painted black aluminium structure and melamine table tops.



Marlene



166

Chair

A sinistra/ On the left

Sedia Marlene in policarbonato giallo.
Marlene chair in yellow polycarbonate.

Sotto / Below

Sedia Marlene in nylon bianco lucido con
sedile imbottito in tessuto Spalmato.
*Marlene chair in glossy white nylon with padded seat in
Spalmato fabric.*



167

Bistrò

Bistrò è un tavolo in acciaio verniciato dalle linee sinuose ispirate al design di inizio Novecento che rievoca nel nome le caffetterie francesi. E proprio negli spazi dell'horeca si trova infatti a suo agio, sia all'interno che all'esterno. Bistrò è disponibile con piano tondo o quadrato, a tre o quattro gambe.

Bistrò is a painted steel table with sinuous lines inspired by the design of the early 900s that evokes through its name the French cafés. It is exactly in the horeca places that it fits in, both indoor and outdoor. Bistrò is available with a circle or squared top, with three or four legs.

Design
Studio Alma

Table

Tavolo Bistrò con telaio quattro gambe in acciaio verniciato bianco e piano in HPL bianco.

Bistrò table with a four-leg frame in white painted steel and top in white HPL.



Bistrò



170

A sinistra/ On the left

Tavolo Bistrò con telaio quattro gambe in acciaio verniciato nero e piano in HPL nero; con telaio a 3 gambe verniciato bianco e piano in HPL bianco.

Bistrò table with a four-leg frame in black painted steel and top in black HPL; with a three-leg frame in white painted steel and top in white HPL.

Sotto / Below

Tavolo Bistrò con telaio quattro gambe in acciaio verniciato nero e piano in HPL nero.

Bistrò table with a four-leg frame in black painted steel and top in black HPL.



171

Meg

Suggerimenti vintage per la poltrona Meg, seduta monoscocca dalle forme monolitiche. Realizzata in polietilene, Meg è ideale per arredare terrazzi e giardini: attuale e contemporanea, confortevole e ironica, è realizzata con materiali riciclabili.

Vintage charm for our Meg armchair, a single seat with monolithic lines. Made of polyethylene, Meg is ideal to furnish terraces and gardens: a modern and contemporary product made in recyclable materials, it results to be extremely comfortable and fancy.

Design
Studio Mario Mazzer

Armchair

Poltrona Meg in polietilene bianco.
Meg armchair in white polyethylene.



Poltrone Meg in polietilene bianco e tavolini Pepper in polietilene bianco e sabbia. Nonò in polipropilene color bianco. Tavolo Mojito alto in alluminio verniciato bianco, piano tondo in HPL bianco.

Meg armchairs in white polyethylene and Pepper coffee tables in white and sand polyethylene. Nonò in white polypropylene. Mojito table in white painted aluminium and HPL round top.



Meg



Poltrone Meg in polietilene colori cipria, antracite, rosso ciliegia e sabbia.

Armchair Meg in polyethylene color pink powder, anthracite, cherry red and sand.

Armchair



Poltrone Meg in polietilene verde boscoe tavolino Pepper in polipropilene giallo ambra.

Meg armchairs in dark green polyethylene and Pepper coffee table in amber yellow polyethylene.

Pepper

Indoor
Outdoor

Pepper è un elemento d'arredo eclettico e polifunzionale, da interpretare in libertà in base ai contesti e alle esigenze. Pratico tavolino di servizio, diventa uno sgabello informale, ma anche una lampada da esterni nella versione dotata di illuminazione. Realizzato in polietilene in un'ampia gamma di colori – dal rosso peperone che dà il nome alla collezione alle tonalità più neutre – si usa sia indoor che outdoor. Pepper è disponibile anche nella versione imbottita per diventare una comoda seduta.

Pepper is an eclectic and multifunctional furniture element, freely interpretable according to contexts and needs. It is a multitasking product. Practical service table, it becomes an informal stool but also an outdoor lamp in the illuminated version. Made of polyethylene in a range of different colours – from pepper red which gives the name to the collection to more neutral shades - it is suitable both for indoors and outdoors. Pepper is also available in an upholstered version to be used as a comfortable seat.

Design
Studio Mario Mazzer

Pouf, stool



Pepper imbottito con tessuto roccia.
Pepper upholstered with roccia fabric.

Pepper



180

Pouf, stool

A sinistra / On the left
Pepper imbottito con tessuto King L Kat.
Poltrona X Big in frassino naturale con
scocca imbottita con tessuto King L Kat.
Tappeto Lana naturale, bouclé misto lana e
viscosa.

*Pepper upholstered with King L Kat fabric.
X Big armchair with nature ashwood base,
upholstered seat in King L Kat fabric.
Lana rug nature color, bouclé mixed wood
and viscose.*

Sotto / Below
Pepper imbottito con ecopelle Touch.
Pepper upholstered with ecoleather Touch.



181

Pepper

Pepper colori: giallo ambra, sabbia, rosso ciliegia, viola bordeaux, bianco, antracite e a terra verde bosco.

Pepper colors: amber yellow, sand, cherry red, violet bordeaux, white, anthracite and on the floor dark green.



Coffee table

Tavolini Pepper in Polietilene rosso ciliegia e in polietilene con luce.

Pepper coffee tables in cherry red polyethylene and polyethylene with light.



Pepper



184

Pouf, stool

A sinistra / On the left

Tavolino Pepper in polietilene luminoso.
Tavoli Ice table con basamento in polietilene sabbia e piano quadrato in polietilene sabbia, con basamento in polietilene bianco e piano tondo in HPL bianco. Poltroncine Jo in polietilene bianco e sabbia.

Pepper coffee table in polyethylene luminous; Ice tables: polyethylene sand base with square polyethylene sand top; polyethylene white base with round white HPL top. Jo armchair in white and sand polyethylene.

Sotto / Below

Tavolino Pepper in polietilene con luce.
Pepper coffee table in polyethylene luminous.



185

Nonò



Indoor
Outdoor

Nonò è una seduta creativa realizzata in polipropilene caricato di fibra di vetro e stampato con tecnologia air moulding. È in assoluto l'evoluzione moderna del classico sgabello, una rivisitazione giovanile e incredibilmente all'avanguardia. Nonò ha una struttura che prevede tre sole gambe, insolita e decisamente unica. Un nuovo modo di sedersi dunque, leggero e dinamico è impilabile e resistente ai raggi UV. Realizzato in quattro colori per adattarsi perfettamente ad ambienti contract e residenziali.

Nonò is a creative seat made of polypropylene loaded with glass fiber and printed with air molding technology. It is absolutely the modern evolution of the classic stool, a youthful and incredibly cutting-edge reinterpretation. Nonò has a structure that includes only three legs, unusual and decidedly unique. A new way of sitting, therefore, light, and dynamic, stackable, and resistant to UV rays. Made in four colors to perfectly adapt to contract and residential environments.

Design
Studio Stefano Soave

Stool



Nonò in polipropilene color antracite.
Nonò, in anthracite polypropylene.



GOOD
DESIGN

Nonò

Nonò in polipropilene color bianco.
Tavolo Mojito alto in alluminio verniciato
bianco, piano tondo in HPL bianco.

*Nonò in white polypropylene.
Mojito table in white painted aluminium and
HPL round top.*

Stool



Nonò



190

Stool

A sinistra / On the left
Nonò in polipropilene color bianco.
Nonò in white polypropylene.

Sotto / Below
Nonò in polipropilene color antracite, lime e
bianco.
*Nonò in anthracite, white and lime
polypropylene.*



191

Indoor
Outdoor

2525 è uno sgabello monoblocco a forma di cono, reso ancora più leggero dalle rientranze che lo fanno assomigliare ai numeri 2 e 5, a seconda di come viene girato. Pratico e impilabile, disponibile in due misure, è progettato per rispondere alle esigenze di bar e ristoranti, che lo usano sia all'interno sia all'esterno, ma anche a quelle di uno spazio domestico, dove rappresenta un'ottima soluzione salvaspazio.

2525 is a single cone-shaped stool, made even lighter thanks to the recesses making it similar to the numbers 2 and 5, according to how it is placed. Practical and stackable, available in two sizes, it has been designed to answer to the needs of bars and restaurants, both for indoor and outdoor use; it can be placed also in private spaces, representing a perfect space-saving solution.

Design
Studio Sergio Mori



Sgabelli 2525 bassi in polietilene arancio.
Tavolo Ice Table con basamento in polietilene
nero e piano in polipropilene nero.

*2525 low stool in orange polyethylene.
Ice Table with black polyethylene base and black
polypropylene top.*



A sinistra / On the left

Sgabelli 2525 impilabili in polietilene color sabbia.

2525 stools, stackable, in sand polypropylene.

Sotto / Below

Sgabello 2525 in polietilene color rosso ciliegia.

2525 stools in Cherry red polypropylene.



Amy

Indoor
Outdoor

Semplicità è una parola chiave per il design di Alma. Valerio Sommella ne offre la sua interpretazione con Amy, sedia dalla grande personalità che unisce forme armoniose a linee dinamiche. Realizzata in polipropilene con tecnologia air moulding, è disponibile con o senza braccioli, anche con cuscino sedile per un maggior comfort. Perfetta per i luoghi del contract per le sue caratteristiche di leggerezza, impilabilità e resistenza ai raggi UV per uso indoor e outdoor, Amy trova collocazione anche negli spazi domestici.

Semplicity is the key word for Alma's design. Valerio Sommella offers his interpretation with Amy, a chair characterized by high personality, harmonious shapes, and dynamic lines. Made of polypropylene injected by air moulding technology, it is available both with or without armrest, also with a pillow seat for a better comfort. Perfect for contract places thanks to its lightness, stackability, and resistance to UV ray to indoor and outdoor use, Amy is suitable for home places, too.

Design
Studio Valerio Sommella

Armchair



Poltroncina Amy in polipropilene verde bosco con cuscino sedile in tessuto Roccia.
Amy armchair in dark green polypropylene with seat cushion in Roccia fabric.

Amy

Chair

Sedie Amy in polipropilene rosso mattone.
Tavoli Mojito con struttura in metallo
verniciato antracite e piano in HPL nero.
*Amy chairs in brick red polypropylene. Mojito
tables with anthracite painted metal structure
and black HPL top.*





Sedia Amy in polipropilene antracite
e poltroncina Amy in polipropilene giallo
ambra.

*Amy chair in anthracite polypropylene
and Amy armchair in yellow amber
polypropylene.*

Amy



202

Chair, armchair

A sinistra / On the left

Sedia Amy in polipropilene bianco e sabbia.
Amy chair in white and sand polypropylene.

Sotto / Below

Sedia Amy impilabile in polipropilene
antracite, sabbia, bianco, rosso mattone e blu
smeraldo.

*Amy stackable chair in anthracite, sand, white,
brick red, and emerald blue polypropylene.*



203

Julie

**Indoor
Outdoor**

Julie unisce linee essenziali che rievocano il design delle sedie del passato a un materiale attualissimo, il polipropilene stampato con la tecnologia air moulding. Resistente ai raggi UV, leggera, impilabile e disponibile in tanti colori diversi, Julie è ideale per tutti i contesti del contract, indoor e outdoor. La versione con cuscino sedile aggiunge un tocco di comfort, rendendola ideale anche per l'ambiente domestico.

Julie combines essentials lines recalling ancient chairs design together with an extremely modern material: gas injected polypropylene, UV-resistant, light weight, stackable, and available in many different colours, Julie is ideal for any type of contract setting, both indoor and outdoor. The pillow version adds a touch of comfort, making it suitable for a home place too.

Design
Studio Tria.De design + Valérie Galli

Chair



Sedia Julie in polipropilene blu viola.
Julie chair in violet blue polypropylene.

Sedie Julie in polipropilene cipria.
Tavoli People con base in acciaio verniciato
bianco e piano tondo in nobilitato.

*Julie chairs in powder pink polypropylene.
People tables with white painted steel base
and round top in melamine.*



Julie

Chair

Sedia Julie in polipropilene bianco e sabbia.
Julie chair in white and sand polypropylene.



208

209

Julie



210

A sinistra/ On the left

Sedia Julie in polipropilene color rosso ciliegia, senza cuscino e con cuscino in ecopelle Touch.

Julie chair in cherry red polypropylene, without cushion and with Touch eco-leather cushion

Sotto / Below

Sedia Julie in polipropilene nero con cuscino in ecopelle Touch.

Julie chair in black polypropylene with cushion in eco leather Touch.



211

Sedie Julie in polipropilene color nero.
Tavolo Grandangolo con struttura in
alluminio verniciato antracite e piano in HPL
color pietra.

*Julie chairs in black-coloured polypropylene.
Grandangolo table with painted anthracite
aluminium structure and stone-coloured
HPL top.*



Puntoquadro

Indoor

Il tavolo allungabile Puntoquadro nasce da forme geometriche semplici e armoniose, caratterizzate da un'originale contrapposizione tra quadro e tondo. Le linee si impreziosiscono di accenti cromatici, che restituiscono alla semplicità funzionale di questo tavolo un carattere forte, da vero protagonista. Le guide in alluminio, tradizionalmente nascoste, qui si mostrano con orgoglio nelle versioni verniciata rosso opaco oppure nera opaca coordinata all'importante fascia anteriore in essenza di frassino. Realizzato interamente in legno, Puntoquadro è un tavolo ricco ed esteticamente bilanciato, che infonde nell'ambiente un'atmosfera calda e accogliente.

Puntoquadro extending table is born from simple and harmonious geometric shapes, characterised by an original contrast between square and round. The lines are embellished with chromatic accents, which give the functional simplicity of this table a strong character of a true protagonist. The traditionally hidden aluminium rails are proudly displayed here in red or black matt painted versions coordinated with the important front band in ash wood. Made entirely of wood and equipped with legs with a large diameter, Puntoquadro is a rich and aesthetically balanced table that infuses the room with a warm and welcoming atmosphere.

Design
Studio Nicola Bonriposi

Table



Gambe in frassino naturale accostate a top stratificato in rovere Asburgo naturale. Fascia anteriore in frassino naturale e guide verniciate in alluminio nero opaco.
Legs in natural ash wood, combined with stratified natural Hasburg durmast oak. Front band in natural ash wood and sliding guides painted in matt black aluminium.



Tavolo Puntoquadro finitura in rovere
Asburgo naturale con fascia in frassino e
guide in alluminio verniciate nero opaco.
Sedia Minnie, finitura frassino naturale e
sedile imbottito.

*Puntoquadro table natural Habsburg durmast
oak finish with ash wood front band and matt
black painted aluminium suding guides.
Minnie chair with natural ash wood finish and
upholstered seat.*

Puntoquadro

Tavolo Puntoquadro finitura in Rovere Asburgo naturale con fascia in frassino tinto rosso e guide in alluminio verniciate rosso opaco.

Sedia Minnie, finitura frassino naturale.

Puntoquadro table with natural Habsburg durmast oak finish. Red-stained ash band and matt red painted aluminium sliding guides.
Minnie chair, natural ash wood finish.

Table



Puntoquadro



220

Table

A sinistra / On the left

Gambe in frassino finitura noce accostate a top in stratificato rovere canaletto. Fascia anteriore in legno tinto rosso e guide verniciate in alluminio rosso opaco.

Walnut-finish ash legs with canaletto oak stratified top. Front band in red stained wood and sliding guides painted in matt red aluminium.

Sotto / Below

Meccanismo di allungamento scorrevole su guide in alluminio con due prolunghe nascoste sotto il piano. Estrazione facile e intuitiva.

Sliding extension mechanism on aluminium guides with two extensions hidden under the top. Easy and intuitive extraction.



221

Puntoquadro



Table

Tavolo allungabile Puntoquadro finitura noce con guide verniciate nero.
Poltroncina Lips, monoscocca in legno e rivestimento in ecopelle touch.

*Puntoquadro extendable table with Walnut finish and black painted sliding guides.
Lips armchair, back in walnut finish upholstered in touch ecoleather.*





Tavolo allungabile Puntoquadro nella versione monocromatica frassino nero e guida verniciata nero, piano e gambe finitura nero.

Sedie Estrosa con struttura in acciaio e sedile e schienale in alluminio anodizzato.

Puntoquadro extendable table in the monochromatic black ash wood version and black painted guide, top and legs in black finish. Estrosa chairs with steel structure and seat and back in anodized aluminium.

Puntoquadro



226

Table

A sinistra/ On the left

Tavolo allungabile Puntoquadro nella versione monocromatica frassino nero e guida verniciata nero, piano e gambe finitura nero.

Puntoquadro extendable table in the monochromatic black ash wood version and black painted guide, top and legs in black finish.

Sotto / Below

Tavolo Puntoquadro in versione monocromatica, con gambe in frassino naturale, piano in stratificato finitura rovere Asburgo naturale e fascia in frassino naturale.

Puntoquadro table in monochrome version, with natural ash legs, stratified top with natural Habsburg durmast oak finish and natural ash band.



227

Rori

Indoor
Outdoor

Il tavolo allungabile Rori è la perfetta sintesi del design fresco e innovativo che contraddistingue Alma. La sua estetica pulita e non invadente, il disegno semplice ma elegante, lo rendono del tutto versatile e inseribile in qualsiasi tipo di ambiente, indoor e outdoor. La gamba ad L in alluminio - visione di una lama per finezza e pulizia - supera la funzione strutturale e conferisce alla solidità del piano una leggerezza visiva inedita. Discreto ma capace di catturare l'attenzione all'occhio che ama i dettagli, Rori è la scelta ideale per la casa giovane, ma perfetta anche per il contract e l'ufficio. Disponibile in versione fissa e allungabile.

The extending table Rori is the perfect synthesis of the fresh and innovative design that characterizing Alma. Its clean, light aesthetics and simple yet elegant structure make it extremely versatile and suitable for any type of environment, indoors or outdoors.

The aluminium L-shaped leg - the fineness and simplicity of the visible blade - goes beyond the structural function and gives the solidity of the top an unprecedented visual lightness.

Discreet but capable of capturing the attention of the eye that loves details, Rori is the ideal choice for the young home, but also perfect for commercial use and offices. Available in fixed and extendable versions, with painted aluminium rails.

Design
Mask Design Studio

Table



Rori è visibile anche a pag 18, 64, 82 e 123. / Rori visible also at p.18, 64, 82 and 123.

Rori

Table

Tavolo Rori con struttura in alluminio verniciata antracite e piano in HPL antracite, versione allungabile.

Poltroncina Jo in polietilene antracite.

Rori table with aluminium structure and HPL top anthracite color, extendable version.

Jo armchair in anthracite polyethylene.



Tavolo Rori con struttura in alluminio verniciato antracite e top in HPL impero nero, versione fissa.
Sedie Minnie con bracciolo in frassino nero.
*Rori table with anthracite-painted aluminium frame and HPL top, fixed version.
Minnie chair with arms, black ash wood.*



Rori

Tavolo Rori con struttura in alluminio verniciato bianco e piano in HPL bianco, versione fissa. Poltroncine Y a 5 razze in alluminio verniciato nero e scocca imbottita in pelle Miami.

*Rori table with aluminium structure white painted and HPL top, fixed version.
Y armchairs black painted with upholstered shell in Miami leather.*





A sinistra/ On the left

Tavolo Rori nella versione allungabile con guide in alluminio verniciato sabbia e piano in HPL sabbia. Poltroncina Scala con struttura sabbia, corda sabbia e cuscino Fortezza.

Rori table in extendable version with aluminium guide sand painted and sand HPL top. Scala armchair with sand steel structure, sand rope and Fortezza cushion.

Sotto / Below

Tavolo Rori nella versione allungabile con guide in alluminio verniciato sabbia e piano HPL sabbia. Poltroncina Scala con struttura sabbia, corda sabbia e cuscino Fortezza.

Rori table in extendable version with aluminium guide sand painted and sand HPL top. Scala armchair with sand steel structure, sand rope and Fortezza cushion.



Rori

Tavolo Rori struttura in alluminio verniciate bianco e piano in laminato bianco. Poltrone Lips con gambe e seduta in frassino tinto noce e rivestimento in tessuto Jojo.

Rori table with white-painted aluminium structure and white laminate top. Lips armchairs with legs and seat in walnut-stained ash and Jojo fabric upholstery.

Table



Grandangolo

Indoor
Outdoor

Grandangolo rappresenta il tavolo ideale per chi desidera un prodotto ricercato, capace di unire stile e funzionalità. Caratterizzato da un'estetica essenziale e da un disegno pulito, dalle forme rettangolari e spigolose, è un tavolo senza tempo.

Pratico e resistente, presenta una struttura in alluminio verniciato e un ripiano in laminato e HPL per esterno. Allungabile, con guide in alluminio di diverse lunghezze; Grandangolo è una scelta pop ed estremamente versatile, adatta ad ambienti indoor e outdoor e facilmente inseribile in diversi contesti, abitativo, contract e aziendale.

Grandangolo is the ideal table for those who want a refined product that combines style and functionality. Characterised by essential aesthetics and a clean design with rectangular and angular shapes, it is a timeless table.

Practical and resistant, it features a painted aluminium frame and a laminate top and HPL for outdoor. Extendable version, with aluminium rails in different lengths; Grandangolo is a pop and extremely versatile choice, suitable for indoor environments and can be effortlessly introduced in different settings, residential, contract and corporate.

Design
Studio Alma

Table



Grandangolo è visibile anche a pag 14, 164 e 212. / Grandangolo visible also at p.14, 164 and 212.

Tavolo Grandangolo con struttura in alluminio verniciato antracite e piano in HPL color pietra.

Sedie Julie in polipropilene color nero.

Grandangolo table with painted anthracite aluminium structure and stone-coloured HPL top. Julie chairs in black-coloured polypropylene.



Grandangolo

Sotto / Below

Tavolo Grandangolo con struttura in alluminio verniciato antracite e piano in nobilitato.

Sedie Marlene in nylon nero lucido.

*Grandangolo table with painted black aluminium structure and melamine table tops.
Marlene chairs in shiny black nylon.*



A destra / On the right

Tavolo Grandangolo con struttura in alluminio verniciato bianco e piano in nobilitato. Sedie X Spider con telaio in tubo d'acciaio rettangolo verniciato bianco e scocca in polipropilene.

*Grandangolo table with painted white aluminium structure and melamine table top.
X chairs with rectangular painted white steel tube frame.*

Table



Tavolo Grandangolo con struttura in alluminio verniciato bianco e piano in nobilitato. Sedie X Spider con telaio in tubo d'acciaio rettangolo verniciato bianco e scocca in polipropilene; divano XBig Too a due posti; tappeto Lana.

Grandangolo table with painted white aluminium structure and melamine table top. X chairs with rectangular painted white steel tube frame; X Bigg Too sofa two seats; Lana rug.



Woodbridge

Ispirato all'estetica orientale, che richiama nel design della struttura simile a un ideogramma, Woodbridge è un tavolo in frassino semplice e poetico. È disponibile in due altezze che si accompagnano rispettivamente a sedie o sgabelli. Diverse le finiture disponibili, che danno al tavolo uno stile classico o nordico.

Inspired by the Oriental aesthetics - that recalls in the frame design similar to an ideogram, Woodbridge is a simple and poetic ashwood table. It is available in two heights which match respectively to chairs and stools. Available in different finishes, Woodbridge is a table with a classic or a nordic style.

Design
Studio Mario Mazzer

Table

Tavolo Woodbridge in frassino tinto noce.
Woodbridge table in walnut stained ash-wood.



Woodbridge



250

Table

A sinistra / On the left

Tavolo Woodbridge altezza sgabello in frassino naturale.
Sgabello Minnie in frassino naturale con sedile imbottito.

Woodbridge stool height version in natural ash-wood.

Minnie stool in natural ash with upholstered seat.

Sotto / Below

Tavolo Woodbridge altezza sgabello in frassino tinto nero.

Woodbridge stool height version in black painted ash-wood.



251

Woodbridge

Sotto / Below

Il piede del tavolo è ottenuto con un elegante incrocio del frassino massello in sezione tonda.

Foot detail of Woodbridge table, created with an elegant intersection between round shape massive ash-wood elements.

A destra / On the right

Tavolo Woodbridge in frassino naturale.
Woodbridge table in natural ash-wood.



252

Table



253

Paloalto

Paloalto è un tavolo che unisce le radici di Alma a un'idea di design contemporaneo. La struttura è composta da due tubi curvati, uniti a terra da due piedi d'acciaio, che sostengono il piano in legno in finitura rovere naturale o scuro. Disponibile in due altezze, si usa come tavolo conviviale o in modo più informale e dinamico.

Indoor

Paloalto is a table conveying Alma's roots to an idea of contemporary design. Its frame is made of two bent tubes, combined on the ground by two steel feet which sustain the wooden top in natural or dark oak finish. Available in two heights, it can be used as meal table or in a more informal way.

Design
Studio Mario Mazzer

Table



Tavolo Paloalto con struttura in acciaio verniciato antracite e piano in frassino tinto noce.

Paloalto table with anthracite painted steel structure and top in walnut-stained ash-wood.

Paloalto



256

Table

A sinistra / On the left

Tavolo Paloalto con struttura in acciaio verniciato bianco e piano in frassino naturale.
Paloalto table with white painted steel structure and top in natural ash-wood

Sotto / Below

Tavolo Paloalto H 1100 mm con struttura in acciaio verniciato bianco e piano in frassino naturale.
Paloalto table H 1100 mm with white painted steel structure and top in natural ash-wood.



257

Malèna

Ispirazione vintage, realizzazione contemporanea. Malèna è un tavolo in acciaio caratterizzato dalla doppia base con profilo conico, la cui forma è ottenuta con particolari lavorazioni di tornitura. Molteplici le versioni del piano, con profilo smussato a 45°.

Vintage inspiration, contemporary production. Malèna is a steel table characterized by a double base with a cone profile, its shape is obtained by a particular turning process. There are manyfold versions of the top, with a 45° beveled edge.

Design
Studio Alma

Table

Tavolo Malèna in acciaio verniciato bianco con piano quadrato in laminato bianco con bordo in MDF laccato. Sedie Julie in polipropilene rosso ciliegia.

Malèna table in white painted steel with square top in white laminate with laquered MDF edge. Julie chairs in cherry red polypropylene.



Tavolo Malèna in acciaio verniciato bianco con piano tondo in HPL bianco.
Sedie Julie in polipropilene color nero.
*Malèna table in white painted steel with square top in white HPL.
Julie chairs in black polypropylene.*



Malèna

Tavoli Malèna con basi in acciaio verniciato,
piano in laminato con bordo in MDF laccato.

*Malèna tables with painted steel bases,
laminated top with laquered MDF edge.*



262

Table



263



A sinistra / On the left

Tavolo Malèna con basi in acciaio verniciato nero, piano in laminato con bordo in MDF laccato.

Malèna tables with painted steel bases, laminated top with laquered MDF edge.

Sotto / Below

Dettaglio bordo in MDF laccato.
Top detail with laquered MDF edge.



Edward

Indoor
Outdoor

La versatilità di Edward risiede nella sua semplicità. Un tavolo passe-partout adatto a essere interpretato in diversi contesti a seconda delle finiture scelte per il piano e la struttura in acciaio, dal ristorante al soggiorno di casa, dalla mensa aziendale alla biblioteca.

The versatility of Edward lies in its simplicity. A passe-partout table suitable to fit in different settings according to the finishes chosen for the top and the steel frame; it is suitable for restaurants and home living rooms, for corporate canteens as well as libraries.

Design
Studio Alma

Table

Tavoli Edward 800x1800 e 800x300 con struttura in acciaio verniciato nero e piano in nobilitato olmo grigio scuro.

Edward tables 800x1800 and 800x300 with structure in black painted steel and top in dark grey melamine.



Edward



268

Table

A sinistra/ On the left

Tavolo Edward con struttura in acciaio verniciato nero e piano in nobilitato nero. Sedia Estrosa con telaio a 4 gambe in acciaio verniciato nero, sedile e schienale in alluminio anodizzato colore nero.

Edward table with base in black painted steel and top in black melamine. Estrosa chairs with 4-legs frame in black painted steel, seat and back in anodized aluminium black color.

Sotto / Below

Tavolo Edward Servetto con struttura in acciaio verniciato nero e piano in nobilitato olmo grigio scuro.

Edward dessert steel table with structure in black painted steel and top in dark grey melamine.



269

Virna

Virna è una collezione di tavoli disegnata da Mario Mazzer. La struttura è in faggio, con gambe leggermente più sottili alle estremità. Per le sue forme semplici e le proporzioni armoniche, Virna si adatta a qualsiasi ambiente.

Virna is a collection of tables designed by Mario Mazzer. The frame is made of beech wood with legs that are slightly thinner at the edge. Thanks to its simple shapes and its harmonious proportions, Virna fits in any location.

Design
Studio Mario Mazzer

Table

Tavolo Virna in faggio naturale con piano tondo in nobilitato bianco.
Virna table in natural beech with round top in white melamine.

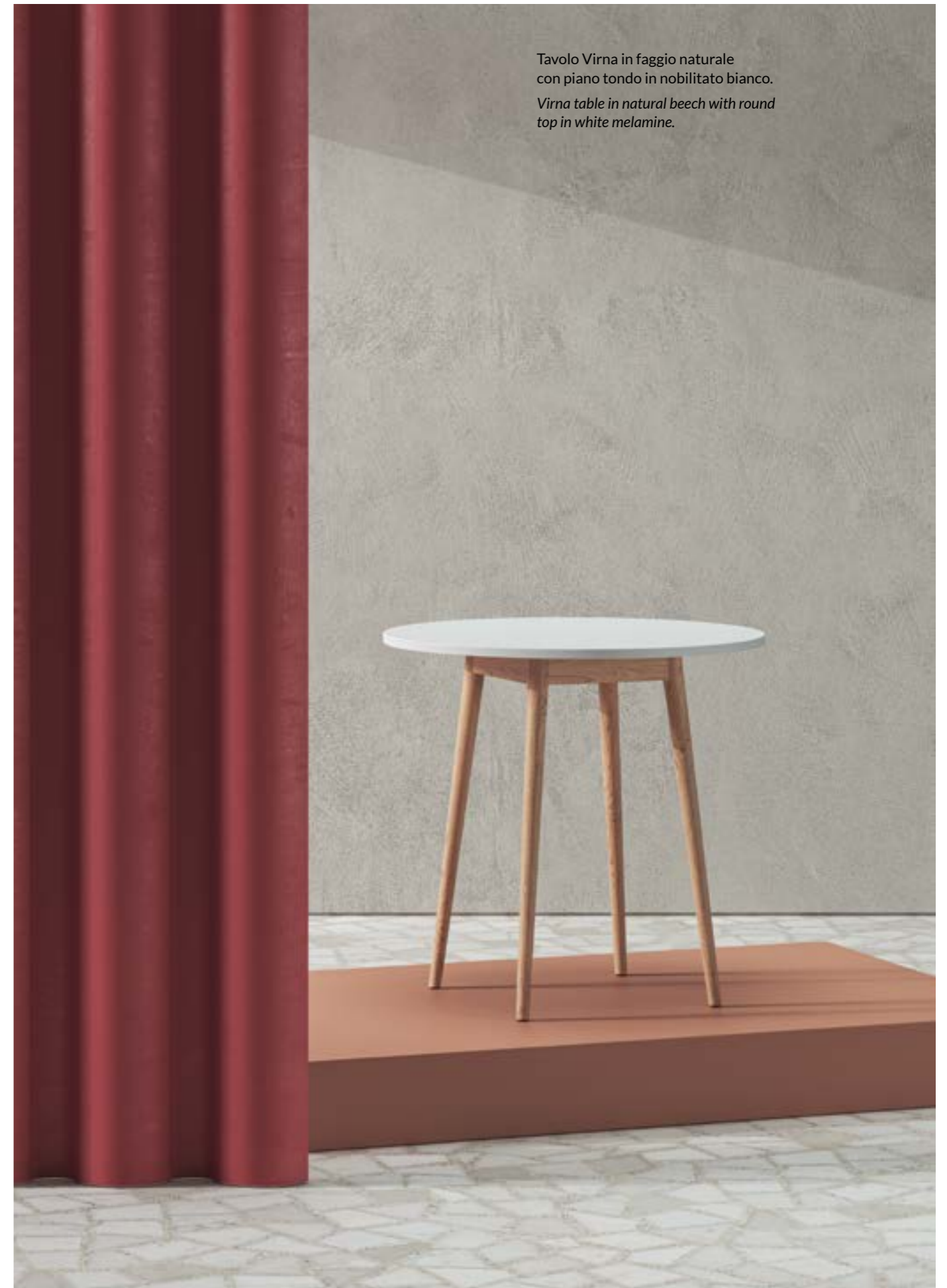

Tavoli Virna in faggio naturale con piano quadrato in nobilitato grigio chiaro; in faggio color noce con piano rettangolare in nobilitato grigio chiaro; in faggio naturale con piano tondo in nobilitato bianco; in faggio nero con piano tondo in nobilitato nero.

Virna tables in natural beech with square top in light grey melamine; in walnut beech with rectangular top in light grey melamine; in natural beech with round top in white melamine; in black beech with round top in black melamine.



Virna



274

Table

A sinistra / On the left

Tavolo Virna in faggio naturale con piano rettangolare in nobilitato bianco. Poltroncine Y con struttura in acciaio verniciato bianco e scocca imbottita in lana cotta Hero.

Virna table in natural beech-wood with rectangular top in white melamine. Y Armchair with white painted steel structure and upholstered Hero seat.

Sotto / Below

Tavolo Virna in faggio naturale con piano quadrato in nobilitato bianco.
Virna table in natural beech with square top in white melamine.



275

Mojito

Tavolino da cocktail indoor o outdoor, Mojito si caratterizza per le linee essenziali e la praticità. Il fusto centrale, con base circolare, è in alluminio verniciato, mentre il piano rotondo e quadrato è disponibile in HPL oppure in nobilitato o solid core.

Little cocktail table for indoors and outdoors, Mojito is characterized by essential lines and functionality. The central stem, with a circular base, is in painted steel, while the circle and the square top is available in HPL or in melamine or solid core.

Design
Studio Alma

**Indoor
Outdoor**

Coffee table, table

Tavoli Mojito alto con base in alluminio verniciato antracite e piano in antracite; medio con base in alluminio verniciato sabbia e piano in HPL sabbia; basso con base in alluminio verniciato bianco e piano in HPL bianco.

Mojito high tables with anthracite painted aluminum base and anthracite top; medium-height version with sand painted aluminum base and sand HPL top; low-height version with white painted aluminum base and white HPL top.



Tavolo Mojito h1100 con struttura in alluminio verniciato bianco e piano in hpl tondo, sgabello Jo in polietilene bianco.

Mojito table h1100 with white painted aluminium frame and round HPL top, Jo stool in white polyethylene



People

Indoor
Outdoor

People è un tavolo trasversale, caratterizzato dalla base in acciaio a quattro razze con piedini per la regolazione della planarità e dal piano personalizzabile nelle forme e nelle finiture. Il suo punto di forza è la semplicità, che lo rende adatto a diversi contesti, dagli spazi domestici a quelli collettivi. Il tavolo è disponibile in tre altezze, anche con piano ribaltabile.

People is a transversal table, characterized by a four-leg metal base with feet to regulate the planarity and by a customizable top in different shapes and finishes. Its clean design allows People to fit to different locations, such as private places as well as public ones. The table is available in three different heights, also with a folding top.

Design
Studio Nicola Cacco

Table

Tavoli People con due basi in acciaio verniciato bianco e piano rettangolare in nobilitato; alto con base in acciaio verniciato bianco e piano tondo in nobilitato.

People tables with two white painted steel bases and rectangular top in melamine; high version with white painted steel base and round top in melamine.



People sono visibili anche a pag. 128, 143 e 206. / People visible also at p. 128, 143 and 206.

Tavoli People con base in acciaio verniciato nero e piano tondo e quadrato in nobilitato, sedie Amy in polipropilene giallo ambra.

People tables with black painted steel base and round and square top in melamine, Amy chairs in yellow amber polypropylene.

ALMA
SPACE



People

Sotto / Below

Tavolo People verniciato nero con meccanismo di ribaltamento e piano in nobilitato nero.

People table with tip-up top mechanism and table top in black melamine.

A destra / On the right

Tavolo People alto in acciaio verniciato nero con piano nero.

Sgabelli Anouk in acciaio verniciato nero e scocca rivestita in ecopelle Touch.

People table high version black painted steel and top in black color.

Anouk stools in painted black steel with upholstered seat in Touch ecoleather.



284

Table



285

Ice Table

Un tavolo robusto che rende protagonista il basamento, un cilindro imponente che si assottiglia avvicinandosi al piano. Realizzato in polipropilene e polietilene, anche con piano in HPL, Ice Table è adatto anche all'uso outdoor.

A thick table that makes its base the protagonist, a majestic cylinder which gets thinner to the top. Made of polypropylene and polyethylene, also with the top in HPL, Ice Table is suitable for outdoors, too.

Design
Studio Alma

**Indoor
Outdoor**

Table



Tavoli Ice Table con basamento in polietilene sabbia e piano tondo in HPL sabbia, con basamento in polietilene bianco e piano quadrato in polipropilene bianco.

Ice Table with base in sand polyethylene and round top in sand HPL, with base in white polyethylene and square top in white polypropylene.

Ice Table



288

Table

A sinistra / On the left

Tavolo Ice in polietilene nero con piano quadrato in polipropilene nero, piano tondo in HPL nero.

Ice table in black polyethylene with square polypropylene black top, round HPL black top.

Sotto / Below

Tavolo Ice in polietilene nero con piano quadrato in polipropilene nero.

Ice table in black polyethylene with square polypropylene black top.



289

Set-up

Indoor
Outdoor

Stefano Soave disegna un tavolo insolito, impilabile grazie alla fessura ricavata sul piano in polietilene. Dettaglio estetico ma soprattutto funzionale, crea l'incastro perfetto per impilare i top una volta sfilati dalla base. Stabile e resistente, per la sua particolarità e ironia Set-up è pensato per locali giovani e di tendenza, dove si usa soprattutto all'esterno.

Stefano Soave designs an unusual table, stackable thanks to the hole on the top in polyethylene. This aesthetical but also functional detail allows the perfect interlocking to stack tops once removed from the base. Steady and resistant, Set-up has been created for young and fashion places, especially for outdoors, thanks to its particularity and easiness.

Design
Studio Stefano Soave

Table



Tavolo Set-up altezza sgabello con base in cemento e piano in polietilene verde bosco, altezza sedia con base in cemento e piano in polietilene rosso ciliegia.

Stool height Set-up table with concrete base and dark green polyethylene top, chair height version with concrete base and cherry red polyethylene top.

Set-up



292

Table

A sinistra / On the left

Piano tavolo Set-up con particolare della vaschetta in polistirolo anche per uso alimentare.

Set-up table top with polystyrene tray detail, suitable also for food use.

Sotto / Below

Dettaglio piano impilato
Stackable top detail



293

Schede prodotto
Product info

**Sedie,
Poltrone,
Divani**

***Chair,
Armchair,
Sofa***

Amarcord

Varianti / Versions



2012
Poltrona con base in acciaio e scocca imbottita.
Armchair with steel base and upholstered shell.



2011
Poltrona con base in acciaio e scocca in rovere con cuscino imbottito.
Armchair with steel base and oak wood shell with upholstered cushion.

Dimensioni / Dimensions

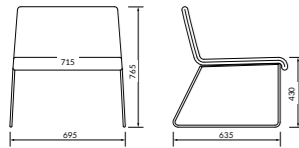

2012 / 2011

Seduta / Seat

Legno / Wood



LE01
Rovere
Oak

Struttura / Frames

Metalli / Metals



CR
Cromato
Chromed



VB
Verniciato bianco
Painted white



VNO
Verniciato nero
Black polished

Rivestimenti / Materials

CAT A Spalmato - Touch
CAT B Origami
CAT B1 Stone Velvet - Jojo
CAT C Capri
CAT D Plush
CAT D1 Velluto Luna
CAT E Hero
CAT PE Pelle Miami

Armchair

Amy

Varianti / Versions



1090
Sedia impilabile in polipropilene colorato.
Stackable chair in colored polypropylene.



1091
Poltroncina impilabile in polipropilene colorato.
Stackable armchair in colored polypropylene.



CS107
Cuscino sedile
Seat cushion

CS107R

Cuscino sedile removibile
Removable seat cushion

Dimensioni / Dimensions

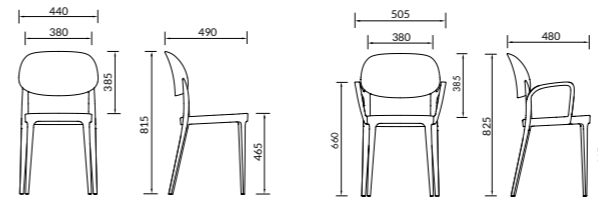

1090

1091

Seduta / Seat

Polipropilene / Polypropylene



A
Antracite
Anthracite



B
Bianco
White



BS
Blu smeraldo
Emerald blue



GA
Giallo ambra
Amber yellow



R2
Rosso mattone
Brick red



S
Sabbia
Sand



VB
Verde bosco
Dark green

Rivestimenti / Materials

CAT A Spalmato - Touch - Roccia - King L Kat

Chair, armchair

OMOLOGAZIONE CL11M



ART. 1090 RAPPORTO DI PROVA N° 213824 EN 1729-1:2015
ART. 1090 RAPPORTO DI PROVA N° 160495 ANSI BIFMA X5.1-2011
ART. 1091 RAPPORTO DI PROVA N° 160525 ANSI BIFMA X5.1-2011

Varianti / Versions



1010

Sedia con struttura a slitta in acciaio, sedile e schienale in alluminio estruso e anodizzato. *Chair with sled steel structure, seat and back in extruded and anodized aluminium.*



1011

Sedia con struttura a 4 gambe in acciaio, sedile e schienale in alluminio estruso e anodizzato. *Chair with a 4-legs steel frame, seat and back in extruded and anodized aluminium.*

Dimensioni / Dimensions

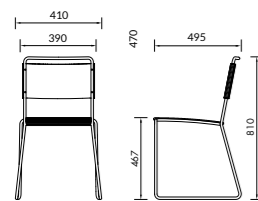

1010

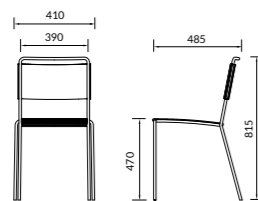

1011

Seduta / Seat

Alluminio / Aluminium



AU01
Nero
Black

AU02
Grigio
Grey

Struttura / Frames

Metalli / Metals



CR
Cromato
Chromed

VA
Verniciato
alluminio
Aluminium
painted

VNO
Verniciato
nero
Black painted

Varianti / Versions



2040

Poltroncina in polietilene colorato. *Coloured polyethylene armchair.*



2041

Poltroncina in polietilene colorato con sedile e schienale imbottiti. *Coloured polyethylene armchair with seat and back upholstered.*



2042

Poltroncina in polietilene colorato con sedile imbottito. *Coloured polyethylene armchair with seat upholstered.*

Dimensioni / Dimensions

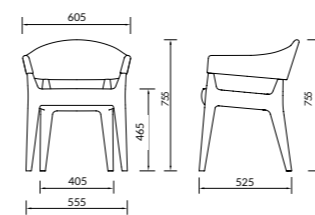

2040 / 2041 / 2042

Seduta / Seat

Polietilene / Polyethylene



A
Antracite
Anthracite

B
Bianco
White

GA
Giallo ambra
Amber yellow

RC
Rosso ciliegia
Cherry red

S
Sabbia
Sand

VB
Verde bosco
Dark green

Rivestimenti / Materials

CAT A Spalmato - Touch - Roccia - King L Kat

Jo Cuoietto

Varianti / Versions



2043

Poltroncinarivestita in cuoietto.
Armchair upholstered in hard leather.

Dimensioni / Dimensions

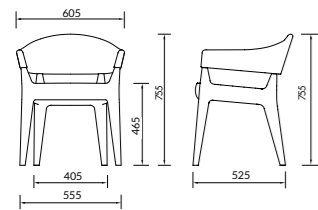

2043

Rivestimenti / Materials

Cat CU Cuoio / Hard leather



CU02
Nero
Black



CU05
Testa di Moro
Brown



CU08
Biscotto
Biscuit



CU09
Burgundi
Burgundy

Chair

OMOLOGAZIONE CL1IM

Julie

Varianti / Versions



1070

Sedia impilabile in polipropilene colorato.
Stackable chair in colored polypropylene.



CS107

Cuscino sedile
Seat cushion

CS107R

Cuscino sedile removibile
Removable seat cushion

Dimensioni / Dimensions

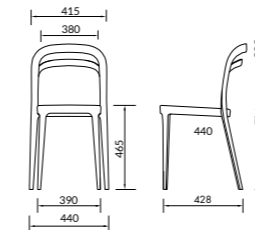

1070

Seduta / Seat

Polipropilene / Polypropylene



B
Bianco
White



BV
Blu viola
Violet blue



C
Cipria
Powder pink



N
Nero
Black



RC
Rosso ciliegia
Cherry red



S
Sabbia
Sand

Rivestimenti / Materials

CAT A Spalmato - Touch - Roccia - King L Kat

Chair

OMOLOGAZIONE CL1IM



RAPPORTO DI PROVA N° 125774 - EN 1728:2000
RAPPORTO DI PROVA N° 132122/130297 - ANSI BIFMA X5.1-2011

Lips

Varianti / Versions



2070
Poltroncina imbottita con gambe e seduta in frassino.
Upholstered armchair with legs and seat in ash-wood.

Dimensioni / Dimensions

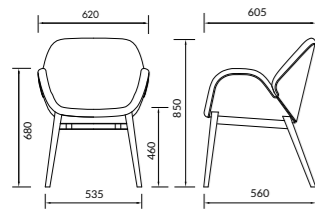

2070

Scocca / Shell

Legno / Wood



LE11 Frassino naturale
Ash
LE12 Frassino tinto noce
Ash stained walnut
LE16 Frassino tinto nero
Ash stained black

Struttura / Frames

Legno / Wood



LE11 Frassino naturale
Ash
LE12 Frassino tinto noce
Ash stained walnut
LE16 Frassino tinto nero
Ash stained black

Rivestimenti / Materials

- CAT A Spalmato - Touch
- CAT B Origami
- CAT B1 Stone Velvet - Jojo
- CAT C Capri
- CAT D Plush
- CAT D1 Velluto Luna
- CAT E Hero
- CAT PE Pelle Miami
- CAT PE1 Pelle Lotus

Armchair



RAPPORTO DI PROVA N° 177232 ANSI-BIFMA X5.1-2011/18

Marlene

Varianti / Versions



1050
Sedia in nylon lucido.
Chair in shining nylon.



1051
Sedia in policarbonato trasparente.
Chair in transparent polycarbonate.



CS105
Cuscino sfoderabile
Removable cushion

Dimensioni / Dimensions

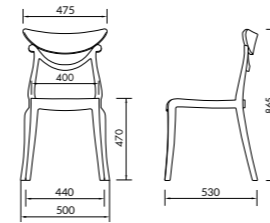

1050 / 1051

Seduta / Seat

Nylon / Nylon



B Bianco lucido
White polished
N Nero lucido
Black polished
RP Rosso pompeiano
Lucido
Pompeian red polished

Policarbonato / Polycarbonate



F Fumé
Fumé
RT Rosso
Red
T Trasparente
Transparent
YT Giallo
Yellow

Rivestimenti / Materials

- CAT A Spalmato - Touch
- CAT B Stone Velvet - Jojo
- CAT D Velluto Luna

Chair



ART. 1050 RAPPORTO DI PROVA N° 108029 ANSI-BIFMA X5.1-2002
ART. 1051 RAPPORTO DI PROVA N° 108030 ANSI-BIFMA X5.1-2002

Marnie

Varianti / Versions



2030
Sedia in frassino.
Ash chair.



2031
Sedia in frassino con schienale
imbottito.
*Ash-wood chair with upholstered
back.*

Dimensioni / Dimensions

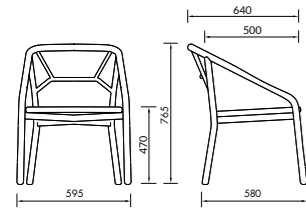

2030 / 2031

Struttura / Frames

Legno / Wood



LE11
Frassino
naturale
Ash

LE12
Frassino tinto
noce
Ash stained
walnut

LE16
Frassino tinto
nero
Ash stained
black

Rivestimenti / Materials

CAT A Spalmato - Touch
CAT B Origami
CAT B1 Stone Velvet - Jojo
CAT C Capri
CAT D Plush
CAT D1 Velluto Luna
CAT E Hero
CAT PE Pelle Miami
CAT PE1 Pelle Lotus

Chair

OMOLOGAZIONE CL1IM



RAPPORTO DI PROVA N. 134033 ANSI-BIFMA X 5.1 - 2011/18

Meg

Varianti / Versions



2060
Poltroncina in polietilene colorato.
Colored polyethylene armchair.

Dimensioni / Dimensions

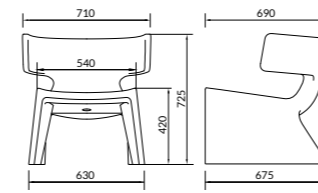

2060

Seduta / Seat

Polietilene / Polyethylene



A
Antracite
Anthracite

B
Bianco
White

C
Cipria
Powder pink

RC
Rosso ciliegia
Cherry red

S
Sabbia
Sand

VB
Verde bosco
Dark green

VX
Viola bordeaux
Violet
bordeaux

Armchair

Minnie

Varianti / Versions



1140
Sedia impilabile in frassino.
Stackable chair in ash wood.



1142
Sedia impilabile in frassino con sedile imbottito.
Stackable chair in ash wood with upholstered seat.



1141
Sedia con braccioli impilabile in frassino.
Stackable chair with armrests in ash wood.



1143
Sedia con braccioli impilabile in frassino con sedile imbottito.
Stackable chair with armrests in ash wood with upholstered seat.

Dimensioni / Dimensions

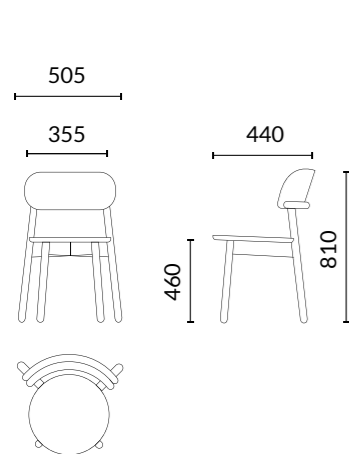

1140 / 1142

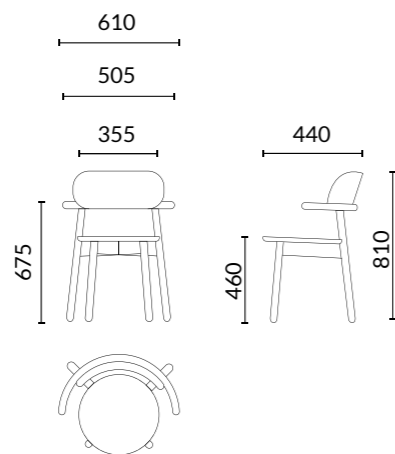

1141 / 1143

Seduta / Seat

Legni / Wood



LE11 Frassino naturale / Natural ash wood
LE12 Frassino noce / Walnut ash wood
LE16 Frassino nero / Black ash wood
LE28 Frassino salvia / Sage wood

Cuscino / Cushion

CAT A Touch - King L kat - Roccia
CAT D1 Velluto Luna

Chair, armchair



RAPPORTO DI PROVA N° 355153 ANSI-BIFMA X5.4 -2020/16
RAPPORTO DI PROVA N° 354878 ANSI-BIFMA X5.4 -2020/16

Lana, Raja

Varianti / Versions



8010
Tappeto da outdoor Raja con intreccio in poliestere riciclato.
Raja outdoor rug with recycled polyester interweaving.



8020
Tappeto Lana indoor annodato a mano con effetto bouclé a nodi in rilievo.
Hand-knotted indoor rug with bouclé effect with raised knots.

Dimensioni / Dimensions

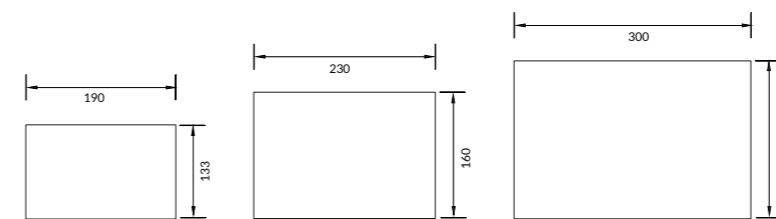

8020

8010 - 8020

Colori / Colors

Outdoor / Outdoor



RA01 Melange nature / Nature
RA02 Melange blu / Blue Melange

Indoor / Indoor



LA01 Nature
LA02 Marrone / Brown
LA03 Grigio / Grey

Rugs

Scala outdoor armchair, sofa

Varianti / Versions



2140

Poltrona outdoor con struttura in acciaio verniciato, corda in polipropilene e cuscini imbottiti.
Outdoor armchair with painted steel frame, polypropylene rope and upholstered cushions.



7140

Divano outdoor a 2 posti con struttura in acciaio verniciato, corda in polipropilene e cuscini imbottiti.
Outdoor 2 seats sofa with painted steel frame, polypropylene rope and upholstered cushions.

Dimensioni / Dimensions

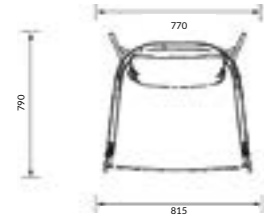

2140

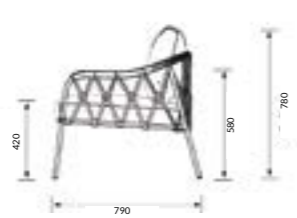

7140

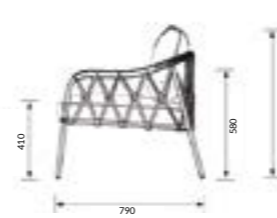
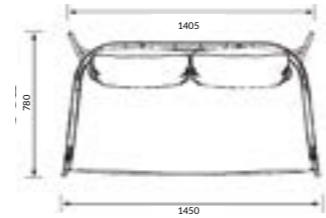

Struttura / Frames

Metalli / Metals



VB Verniciato bianco
White painted
VS Verniciato sabbia
Sand painted
VT Verniciato antracite
Anthracite painted

Corda / Rope



TR001 Sabbia
Sand
TR002 Antracite
Anthracite
TR003 Vinaccia
Bordeaux

Rivestimenti / Materials

CAT C Fortezza - Itaca
CAT D Tropea
CAT E Salina

Scala outdoor chair

Varianti / Versions



2150

Poltroncina outdoor con struttura in acciaio verniciato, corda in polipropilene e cuscino imbottito.
Outdoor little armchair with painted steel frame, polypropylene rope and upholstered cushion.



CB215

Cuscino schienale
Back cushion

Dimensioni / Dimensions

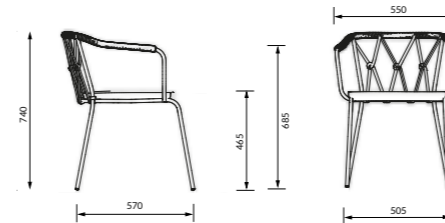

2150

Struttura / Frames

Metalli / Metals



VB Verniciato bianco
White painted
VS Verniciato sabbia
Sand painted
VT Verniciato antracite
Anthracite painted

Corda / Rope



TR001 Sabbia
Sand
TR002 Antracite
Anthracite
TR003 Vinaccia
Bordeaux

Rivestimenti / Materials

CAT C Fortezza - Itaca
CAT D Tropea
CAT E Salina

Scala indoor armchair, sofa

Varianti / Versions



2130

Poltrona imbottita con struttura in acciaio verniciato.
Upholstered armchair with steel painted frame.



7130

Divano imbottito con struttura in acciaio verniciato.
Upholstered sofa with painted steel structure.

Dimensioni / Dimensions

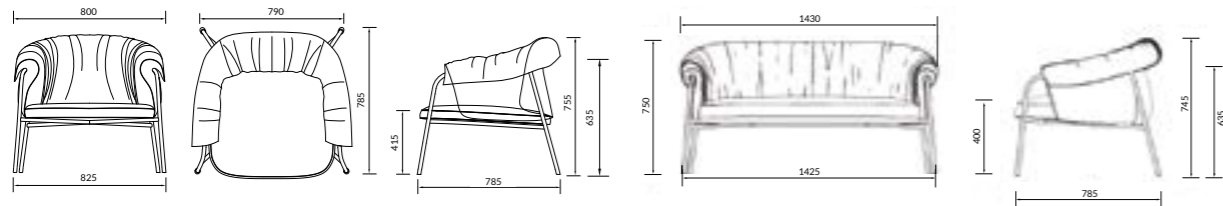

2130

7130

Struttura / Frames

Metalli / Metals



VAG
Bronzo
Bronze

VNO
Verniciato nero
Black polished

Rivestimenti / Materials

CAT A Spalmato - Touch
CAT B Origami
CAT B1 Stone Velvet - Jojo
CAT C Capri
CAT D Plush
CAT D1 Velluto Luna
CAT E Hero
CAT PE Pelle Miami
CAT PE1 Pelle Lotus

312

Scala chair indoor

Varianti / Versions



1130

Sedia imbottita con struttura in acciaio verniciato.
Upholstered chair with painted steel structure.

Dimensioni / Dimensions

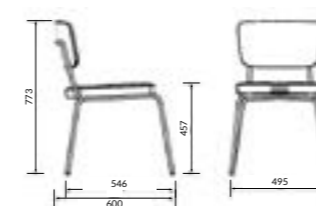

1130

Struttura / Frames

Metalli / Metals



VAG
Bronzo
Bronze

VNO
Verniciato nero
Black polished

Rivestimenti / Materials

CAT A Spalmato - Touch
CAT B Origami
CAT B1 Stone Velvet - Jojo
CAT C Capri
CAT D Plush
CAT D1 Velluto Luna
CAT E Hero
CAT PE Pelle Miami
CAT PE1 Pelle Lotus

312

313



1081
 Sedia slitta con scocca in polipropilene (X sled).
 Sled chair with Polypropylene shell (X sled).



1082
 Sedia 4 gambe tubo rettangolo in acciaio verniciato con scocca in polipropilene (X Spider).
 4-legs rectangular steel tube painted chair with polypropylene shell (X Spider).



1083
 Sedia 4 gambe in frassino con scocca in polipropilene (X Wood).
 4-legs ash wood frame with polypropylene shell (X Wood).

Dimensioni / Dimensions

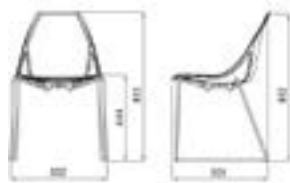

1081

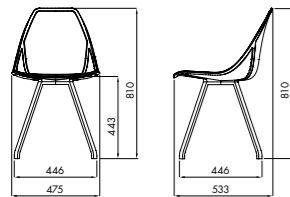

1082

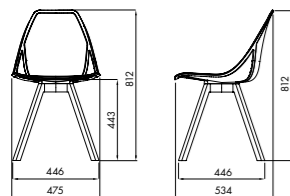

1083



CS108S
 Cuscino sedile (x soft).
 Seat cushion (x soft).



CS108T
 Cuscino intero (x soft).
 Shell cushion (x soft).

Scocca / Shell

Polipropilene / Polypropylene



Struttura / Frames

Metalli / Metals

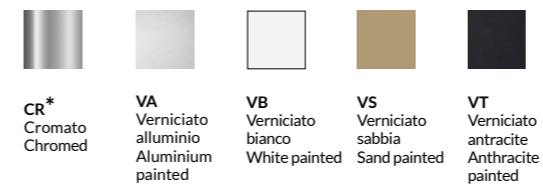

*Solo per cod. 1081
 Only for 1081 code

Legno / Wood



Rivestimenti / Materials

CAT A Spalmato - Touch - Roccia - King L Kat
 CAT B1 Stone Velvet - Jojo
 CAT D1 Velluto Luna

X Beam

OMOLOGAZIONE CL1IM



5082

Panca in acciaio verniciato a 2 posti con scocche in polipropilene.
2 places bench with painted steel frame and polypropylene seats.

5083

Panca in acciaio verniciato a 3 posti con scocche in polipropilene.
3 places bench with painted steel frame and polypropylene seats.

5084

Panca in acciaio verniciato a 4 posti con scocche in polipropilene.
4 places bench with painted steel frame and polypropylene seats.

Dimensioni / Dimensions

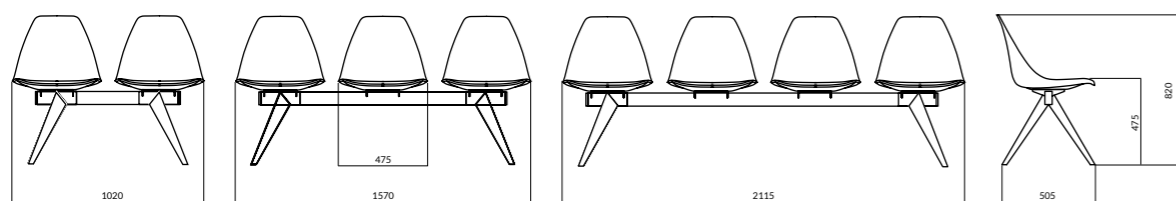

5082

5083

5084

Scocca / Shell

Polipropilene / Polypropylene



A
Antracite
Anthracite

B
Bianco
White

S
Sabbia
Sand

Struttura / Frames

Metalli / Metals



VA
Verniciato alluminio
Aluminium painted

VB
Verniciato bianco
White painted

VS
Verniciato sabbia
Sand painted

VT
Verniciato antracite
Anthracite painted

Rivestimenti / Materials

CAT A Spalmato - Touch - Roccia - King L Kat
CAT B1 Stone Velvet - Jojo
CAT D1 Velluto Luna

X Big

OMOLOGAZIONE CL1IM



RAPPORTO DI PROVA N° 175689-174708-175409-172816 ANSI-BIFMA X5.1-2011/18

Varianti / Versions



2050

Poltrona imbottita con base in frassino.
Upholstered lounge armchair in ash-wood.

2051

Poltrona imbottita con base in acciaio verniciato a sezione rettangolare.
Upholstered lounge armchair with base in painted rectangular steel tube.

2053

Poltrona imbottita con base girevole 4 razze in alluminio.
Upholstered 4-star swivel lounge armchair.

Dimensioni / Dimensions

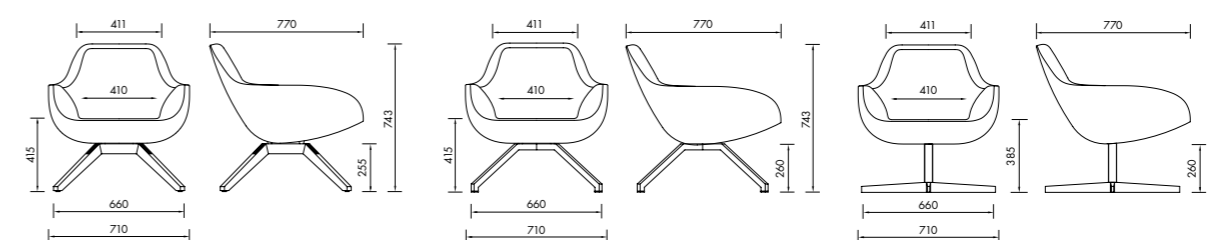

2050

2051

2053

Struttura / Frames

Metalli / Metals



VB
Verniciato bianco
White painted

VT
Verniciato antracite
Anthracite painted

Alluminio / Aluminum

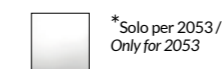

AU 09*
Lucido
Polished

Legno / Wood



LE11
Frassino naturale
Ash

LE12
Frassino tinto noce
Ash stained walnut

LE16
Frassino tinto nero
Ash stained black

Rivestimenti / Materials

CAT A Spalmato - Touch
CAT B Origami
CAT B1 Stone Velvet - Jojo
CAT C Capri
CAT D Plush
CAT D1 Velluto Luna
CAT E Hero
CAT PE Pelle Miami
CAT PE1 Pelle Lotus

X 2Big

OMOLOGAZIONE CL11M



RAPPORTO DI PROVA N° 175689-174708-175409-172816 ANSI-BIFMA X5.1-2011/18



2054

Poltrona imbottita con poggiatesta e base in frassino.
Upholstered lounge armchair in ash-wood with headrest.



2055

Poltrona imbottita con poggiatesta e base in acciaio verniciato a sezione rettangolare.
Upholstered lounge armchair with base in painted rectangular steel tube with headrest.



2057

Poltrona imbottita con poggiatesta e base girevole 4 razze in alluminio.
Upholstered 4-star swivel lounge armchair with headrest.

Dimensioni / Dimensions

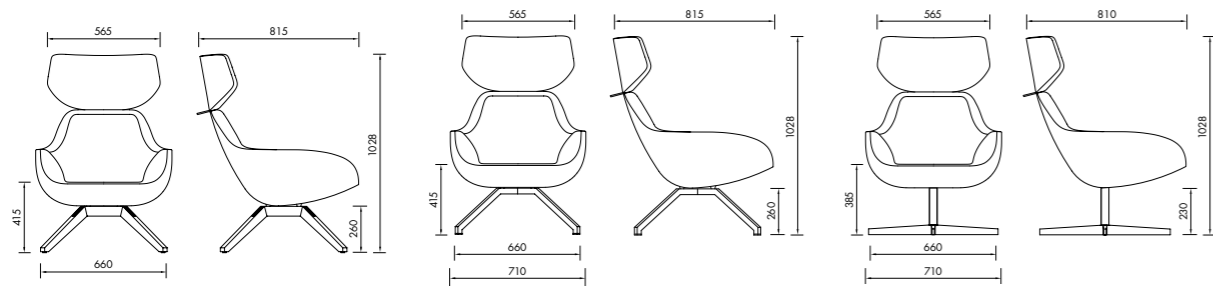

2054

2055

2057

Struttura / Frames

Metalli / Metals



VB
Verniciato bianco
White painted

VT
Verniciato antracite
Anthracite painted

Alluminio / Aluminum



AU 09*
Lucido
Polished

*Solo per 2057 /
Only for 2057

Legno / Wood



LE11
Frassino naturale
Ash

LE12
Frassino tinto noce
Ash stained walnut

LE16
Frassino tinto nero
Ash stained black

Rivestimenti / Materials

CAT A Spalmato - Touch
CAT B Origami
CAT B1 Stone Velvet - Jojo
CAT C Capri
CAT D Plush
CAT D1 Velluto Luna
CAT E Hero
CAT PE Pelle Miami
CAT PE1 Pelle Lotus

X Big Too

Varianti / Versions



7012P

Divano 2 posti con base in frassino tinto.
Sofa 2-seat with ash wood stained frame.



7013P

Divano 3 posti con base in frassino tinto.
Sofa 3-seat with ash wood stained frame.

Dimensioni / Dimensions

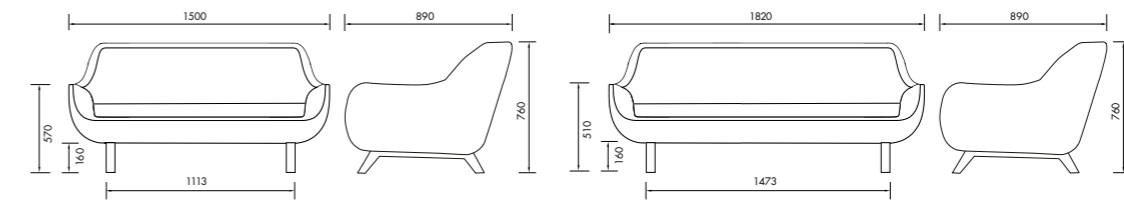

7012P

7013P

Struttura / Frames

Legno / Wood



LE11
Frassino naturale
Ash

LE12
Frassino tinto noce
Ash stained walnut

LE16
Frassino tinto nero
Ash stained black

Rivestimenti / Materials

CAT A Spalmato - Touch
CAT B Origami
CAT B1 Stone Velvet - Jojo
CAT C Capri
CAT D Plush
CAT D1 Velluto Luna
CAT E Hero
CAT PE Pelle Miami
CAT PE1 Pelle Lotus

X Pouf

Varianti / Versions



2080

Pouf con base in frassino e sedile imbottito.
Pouf with ash wood base and upholstered seat.



2081

Pouf con base fissa in acciaio verniciato sezione rettangolare e sedile imbottito.
Pouf fixed with painted steel frame with rectangular shape and upholstered seat.



2083

Pouf con base a 4 razze in alluminio girevole e sedile imbottito.
Pouf with swivel 4 stars aluminum frame and upholstered seat.

Dimensioni / Dimensions

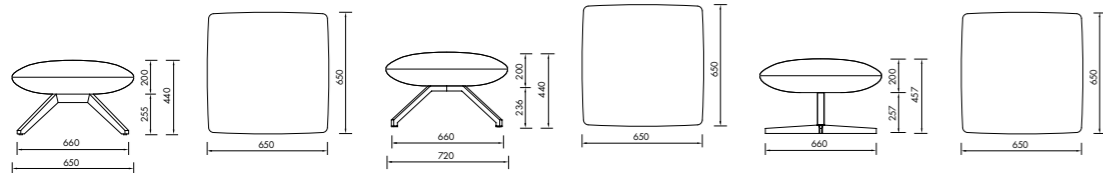

2080

2081

2083

Struttura / Frames

Metalli / Metals



VB
Verniciato bianco
White painted

VT
Verniciato antracite
Anthracite painted

Alluminio / Aluminum



AU 09*
Lucido
Polished

*Solo per 2083 /
Only for 2083

Legno / Wood



LE11
Frassino naturale
Ash

LE12
Frassino tinto noce
Ash stained walnut

LE16
Frassino tinto nero
Ash stained black

Rivestimenti / Materials

CAT A Spalmato - Touch
CAT B Origami
CAT B1 Stone Velvet - Jojo
CAT C Capri
CAT D Plush
CAT D1 Velluto Luna
CAT E Hero
CAT PE Pelle Miami

X Big foot

Varianti / Versions



7020

Poggiatesta con struttura in frassino e sedile imbottito.
Foot rest with ash wood base and upholstered seat.

Dimensioni / Dimensions

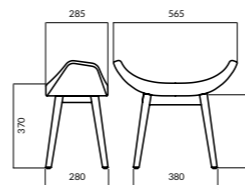

7020

Struttura / Frames

Metalli / Metals



VB
Verniciato bianco
White painted

VT
Verniciato antracite
Anthracite painted

Alluminio / Aluminum



AU 09*
Lucido
Polished

*Solo per 2083 /
Only for 2083

Legno / Wood



LE11
Frassino naturale
Ash

LE12
Frassino tinto noce
Ash stained walnut

LE16
Frassino tinto nero
Ash stained black

Rivestimenti / Materials

CAT A Spalmato - Touch
CAT B Origami
CAT B1 Stone Velvet - Jojo
CAT C Capri
CAT D Plush
CAT D1 Velluto Luna
CAT E Hero
CAT PE Pelle Miami

Y Armchair

OMOLOGAZIONE CL1IM

Varianti / Versions



2090
Poltroncina impilabile 4 gambe in acciaio verniciato con scocca in polietilene o imbottita. (Y four)
Stackable 4-leg armchair in painted steel with polyethylene or upholstered shell. (Y four)



2091
Poltroncina 4 gambe tubo rettangolare con scocca in polietilene o imbottita. (Y spider)
4-leg armchair with rectangular tube and polyethylene or upholstered shell. (Y spider)



2092
Poltroncina 4 gambe in frassino con scocca in polietilene o imbottita. (Y wood)
4-leg armchair in ash-wood with polyethylene or upholstered shell. (Y wood)



2095
Poltroncina 4 gambe tubo conico con scocca in polietilene o imbottita. (Y cone)
4-Leg armchair with conical tube and polyethylene or upholstered shell. (Y cone)

Dimensioni / Dimensions

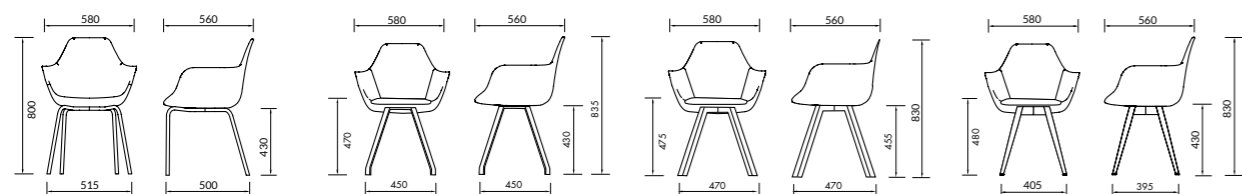

2090

2091

2092

2095

Scocca / Shell

Polietilene / Polyethylene



A Antracite Anthracite
B Bianco White
GA Giallo ambra Amber yellow
RC Rosso ciliegia Cherry red
S Sabbia Sand
VB Verde bosco Dark green
VX Viola bordeaux Violet bordeaux

Struttura / Frames

Metalli / Metals



VA Verniciato alluminio Aluminium painted
VB Verniciato bianco White painted
VS Verniciato sabbia Sand painted
VT Verniciato antracite Anthracite painted

Legno / Wood



LE11 Frassino naturale Ash
LE12 Frassino tinto noce Ash stained walnut
LE16 Frassino tinto nero Ash stained black

Rivestimenti / Materials

CAT A Spalmato - Touch - Roccia - King L Kat
CAT B Origami
CAT B1 Stone Velvet - Jojo
CAT C Capri
CAT D Plush
CAT D1 Velluto Luna
CAT E Hero

Y Armchair

OMOLOGAZIONE CL1IM

Varianti / Versions



2096
Poltroncina girevole 4 razze in alluminio con scocca in polietilene o imbottita. (Y work)
4-Spokes aluminium base armchair, swivel with polyethylene or upholstered shell. (Y work)



2099
Poltroncina girevole 5 razze in alluminio con ruote piroettanti e scocca in polietilene o imbottita. Regolabile in altezza con meccanismo a gas. (Y work)
5-Spokes aluminium base armchair, swivel with gas regulation and polyethylene or upholstered shell. (Y work)



CS209
Cuscino sedile (y soft)/imbottita
Seat cushion (y soft)/upholstered

Dimensioni / Dimensions

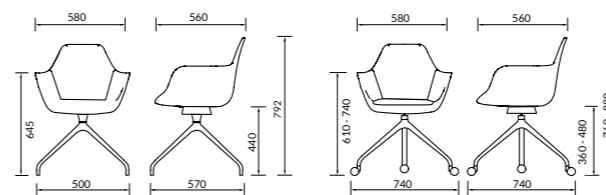

2096

2099

Scocca / Shell

Polietilene / Polyethylene



A Antracite Anthracite
B Bianco White
GA Giallo ambra Amber yellow
RC Rosso ciliegia Cherry red
S Sabbia Sand
VB Verde bosco Dark green
VX Viola bordeaux Violet bordeaux

Struttura / Frames

Alluminio / Aluminum



AU 09 Lucido Polished
VNO Verniciato nero Black painted

Rivestimenti / Materials

CAT A Spalmato - Touch - Roccia - King L Kat
CAT B Origami
CAT B1 Stone Velvet - Jojo
CAT C Capri
CAT D Plush
CAT D1 Velluto Luna
CAT E Hero

**Tavoli,
Tavolini**

***Table,
Coffee table***

Varianti / Versions



3060

Tavolino H 256 con piano in MDF laccato opaco.
Coffee table H 256 with MDF top matt lacquered.



3061

Tavolino H 495 con piano in MDF laccato opaco.
Coffee table H 495 with MDF top matt lacquered.

Dimensioni / Dimensions

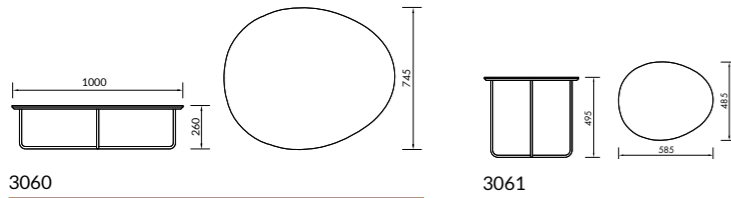

3060

3061

Colori piano / Top colors

Mdf / Mdf



LE05B Laccato bianco
White laquered
LE07 Laccato nero
Black laquered

Struttura / Frames

Metalli / Metals



CR Cromato
Chromed
VB Verniciato bianco
White polished
VNO Verniciato nero
Black polished

Varianti / Versions



3070

Tavolo con telaio 3 gambe in acciaio verniciato e piano in HPL sp. 10.
Table with a 3-leg frame in painted steel and top in HPL th 10.



3071

Tavolo con telaio 4 gambe in acciaio verniciato e piano in HPL sp.10.
Table with a 4-leg frame in painted steel and top in HPL th 10.

Dimensioni / Dimensions

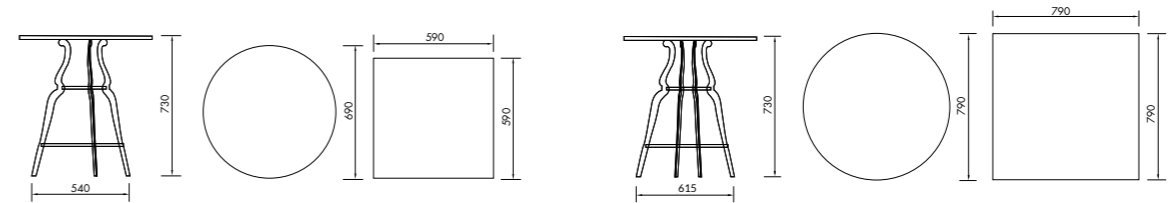

3070

3071

Colori piano / Top Colors

Laminato nobilitato / Laminated melamine



B Bianco opaco
Matt white
N* Nero opaco
Matt black

* Solo per laminato
Only laminated

Solid core / Solid core



HB Bianco
White

Hpl / Hpl



HB Bianco
White
HN Nero
Black
HR# Rosso
Red

Struttura / Frames

Metalli / Metals



VB Verniciato bianco
White painted
VNO Verniciato nero
Black painted
VR# Verniciato rosso opaco
Red matt painted

Finitura in eliminazione
Finish in low stock

Varianti / Versions



3700
Tavolo in acciaio, piede 890, piano con bordi massellati sp. 40.
Steel table, foot 890, multilayer top with solid wood edges, th 40.



3701
Tavolo in acciaio, piede 650, piano con bordi massellati sp. 40.
Steel table, foot 650, multilayer top with solid wood edges, th 40.



3702
Tavolo allungabile in acciaio, piede 650, piano in laminato da 1400+500+500x900 con bordo sp.70.
Extendable steel frame table, foot 650, laminated top dimension 1400+500+500x900, edge th 70.



3703
Tavolo in acciaio, piede 890, piano in HPL sp. 10.
Steel frame table, foot 890, HPL top th 10.

Dimensioni / Dimensions

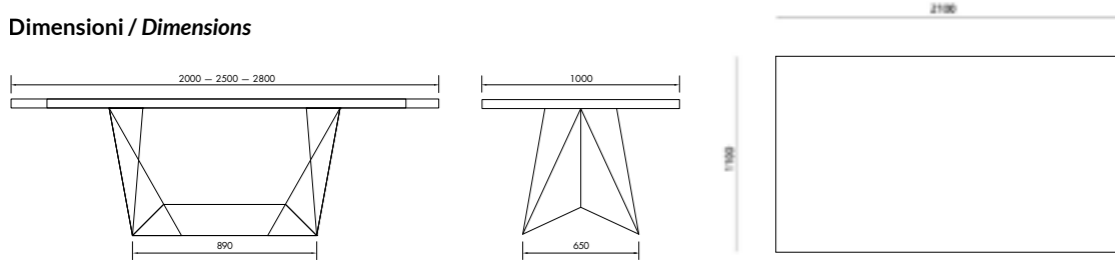

3700

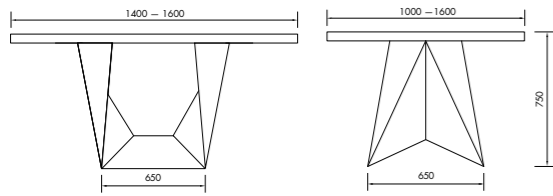

3701

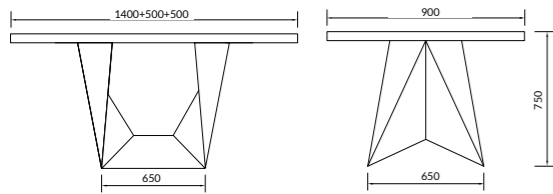

3702

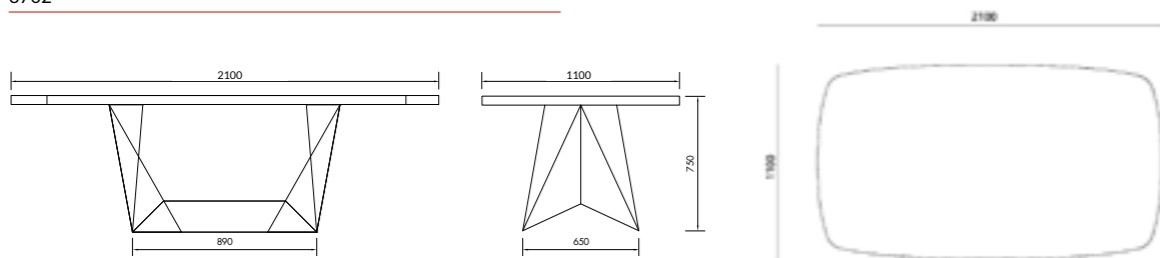

3703

Struttura / Frames

Metalli / Metals

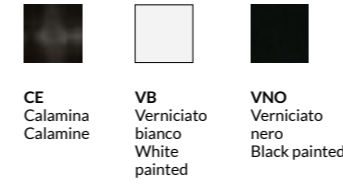

Colori piano / Top colors

Legno / Wood



Laminato / Laminated



*Solo per versione allungabile / Only for extendable version

Hpl / Hpl



Edward

Varianti / Versions



3030

Tavolo in due altezze in acciaio con piano in nobilitato sp. 20 o in HPL sp. 10.
Steel table in two heights with melamine top th 20 or HPL top th 10.



3030 SERVETTO

Tavolo Servetto in due altezze in acciaio con piano in nobilitato sp. 20 o in HPL sp. 10.
Dessert steel table in two heights with melamine top th 20 or HPL top th 10.

Dimensioni / Dimensions

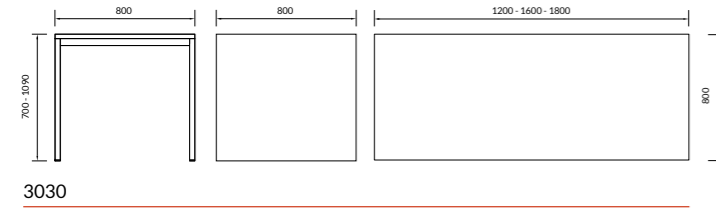

3030

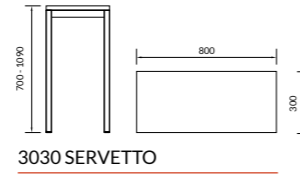

3030 SERVETTO

Struttura / Frames

Metalli / Metals



CR Cromato Chromed
VA Verniciato alluminio Aluminium painted
VB Verniciato bianco White painted
VNO Verniciato nero Black painted

Colori piano / Top colors

Hpl / Hpl



HB Bianco White
HN Nero Black
HS Sabbia Sand

Laminato nobilitato / Laminated melamine



B Bianco White
C Grigio chiaro Light grey
N* Nero Black
T* Antracite Anthracite

*Solo per laminato Only laminated

Table

Grandangolo

Table

Varianti / Versions



380012585

Tavolo allungabile mm 1250+400+400X850 con struttura in alluminio verniciato e piano in nobilitato sp. 20 o in HPL sp. 10.
Extendable table mm 1250+400+400X850 with aluminium frame and melamine top th 20 or HPL top th 10.



380014085

Tavolo allungabile mm 1400+400+400X850 con struttura in alluminio verniciato e piano in nobilitato sp. 20 o in HPL sp. 10.
Extendable table mm 1400+400+400X850 with aluminium frame and melamine top th 20 or HPL top th 10.



380016085

Tavolo allungabile mm 1600+400+400X850 con struttura in alluminio verniciato e piano in nobilitato sp. 20 o in HPL sp. 10.
Extendable table mm 1600+400+400X850 with aluminium frame and melamine top th 20 or HPL top th 10.

Dimensioni / Dimensions

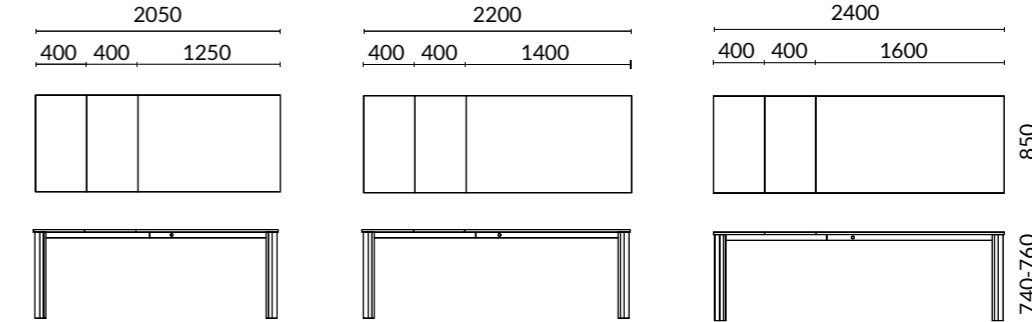

380012585

380014585

380016585

Struttura / Frames

Metalli / Metals



VT Verniciato antracite Anthracite painted
VB Verniciato bianco White painted

Colori piano / Top colors

HPL / Solid core



HB Bianco White
HBR Brown lucido Shiny brown
HCO Corten Corten
HIN Impero nero Black Impero
HMC Calacatta Calacatta



HPI Pietra Stone
HN Nero Black
HS Sabbia Sand

Nobilitato / Melamine



B Bianco White
C Grigio chiaro Light grey
OG Olmo Grigio scuro Dark grey olmo
R Rovere Oak
RG Rovere grigio Grey oak
WR Wengé Wengé
N* Nero Black

*Solo laminato Only laminated

Ice Table

Varianti / Versions



3690

Tavolo H 730 in polietilene con piano in polipropilene colorato.
Table H 730 with polyethylene base and colored polypropylene top.



3691

Tavolo H 710 in polietilene con piano sp. 10 tondo o quadrato in HPL.
Table H 710 in polyethylene with top th. 10 round or square in HPL.

Dimensioni / Dimensions

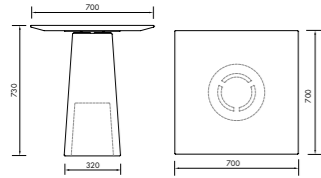

3690

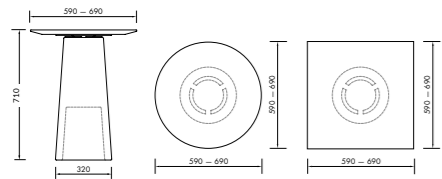

3691

Piano e base / Top and base

Polietilene / Polyethylene



B Bianco / White
N Nero / Black
S Sabbia / Sand

Piano / Top

Hpl / Hpl



HB Bianco / White
HN Nero / Black
HS Sabbia / Sand

Table

Magenta

Coffee table

Varianti / Versions



3750H35

Tavolino H 365 con piano ovale 1220x820.
Coffee table H 365 oval top 1220x820.



3750H55

Tavolino H 520 con piano tondo Ø 500.
Coffee table H 520 with top Ø 500.

Dimensioni / Dimensions

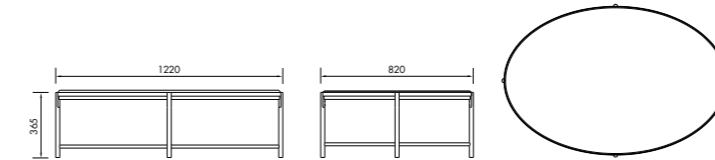

3750H35

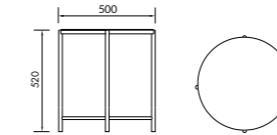

3750H55

Colori Piano / Top colors

Mdf / Mdf



LE05B Laccato bianco / White laquered
LE07 Laccato nero / Black laquered
LE25 Laccato grigio ghiaia / Pebble grey laquered
LE26 Laccato rosso ossido / Red oxyde laquered

Marmo / Marble



MCL * Marmo Carrara lucido / Carrara marble polished
MNM * Nero marquina / Black marquina

* La tonalità delle superfici in pietra naturale può variare su ognuno dei pezzi prodotti.
The nuance of the surfaces in natural stone may change on every piece produced.

Struttura / Frames

Metalli / Metals



VNO Verniciato nero / Black polished

Varianti / Versions



3012 - 3014

Tavolo H 740 con 2 basi Ø 600 - Ø 700 in acciaio verniciato, piano in laminato con bordo in MDF laccato inclinato sp. 30.
Table H 740 structure with 2 bases Ø 600 - Ø 700 in painted steel, laminated top with laquered MDF chamfered edge th 30.



3010H5 - 3010H7

Tavolo H 500 - H740 con base Ø 470 in acciaio verniciato, piano in laminato con bordo in MDF laccato inclinato sp. 30.
Table H 500 - H740 structure with base Ø 470 in painted steel, laminated top with laquered MDF chamfered edge th 30.



3011 - 3013

Tavolo H 740 con base Ø 600 - Ø 700 in acciaio verniciato, piano in laminato con bordo in MDF laccato inclinato sp. 30.
Table H 740 structure with base Ø 600 - Ø 700 in painted steel, laminated top with laquered MDF chamfered edge th 30.



3010H1

Tavolo H 1100 con base Ø 470 in acciaio verniciato, piano in laminato con bordo in MDF laccato inclinato sp. 30.
Table H 1100 structure with base Ø 470 in painted steel, laminated top with laquered MDF chamfered edge th 30.

Dimensioni / Dimensions

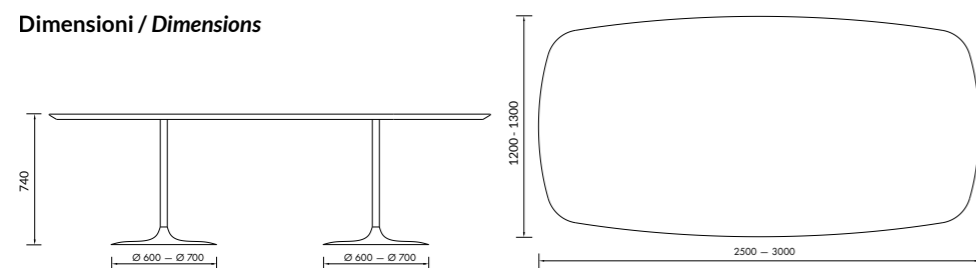

3012 - 3014

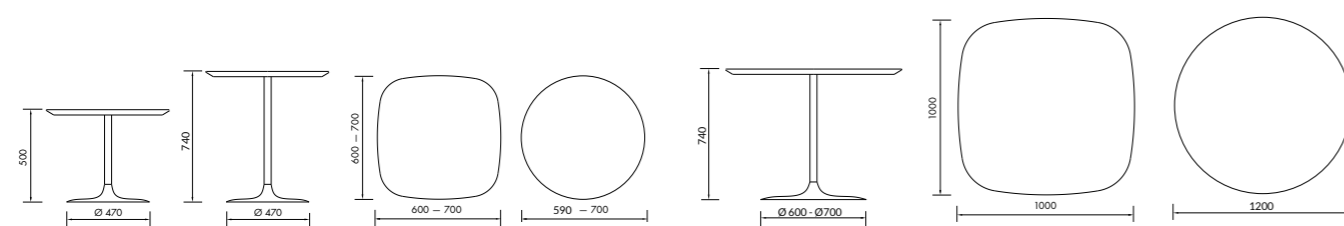

3010H5 - 3010H7

3011 - 3013

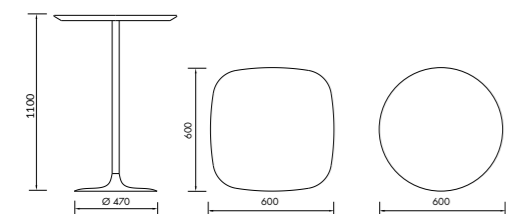

3010H1

Colori piano / Top colors

Hpl / Hpl



HB
Bianco
White

HN
Nero
Black

Solid core / Solid core



HB
Bianco
White

Laminato / Laminated



B
Bianco lucido
Polished
white

N
Nero lucido
Polished black

B
Bianco opaco
Matt white

N
Nero opaco
Matt white

Struttura / Frames

Metalli / Metals



VB
Verniciato
bianco
White
painted

VB1
Verniciato
bianco lucido
Polish white
painted

VNO
Verniciato
nero
Black
painted

VN
Verniciato
nero lucido
Polish black
painted

Marnie

Varianti / Versions



3650
Tavolo 3 gambe in frassino con piano in MDF laccato sp. 25 o in HPL sp.10.
3-Leg ash-wood table with MDF laquered top th 25 or HPL top th 10.



3651
Tavolo 4 gambe in frassino con piano in MDF laccato sp. 25 o in HPL sp.10.
4-Leg ash-wood table with MDF laquered top th 25 or HPL top th 10.



3652 - 3653
Tavolo 4 gambe in frassino con piano in MDF laccato sp. 25 o in HPL sp.10.
4-Leg ash-wood table with MDF laquered top th 25 or HPL top th 10.

Dimensioni / Dimensions

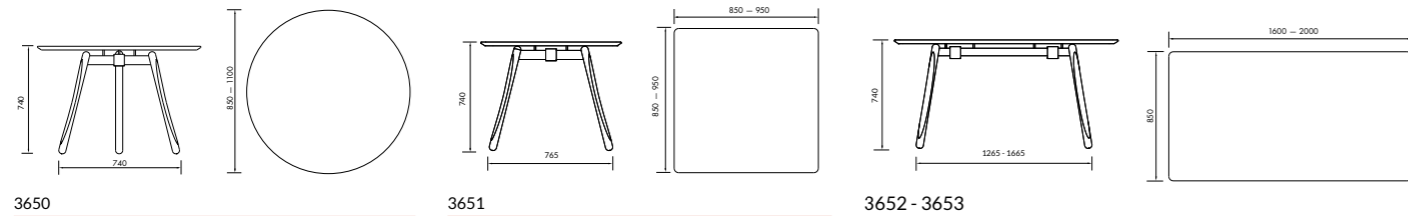

Colori piano / Top colors

Mdf / Mdf



LE05B
Laccato bianco freddo
Cold white laquered

Hpl / Hpl



HB
Bianco
White



HBR
Brown lucido
Shiny brown



HMC
Calacatta
Calacatta



HCO
Corten
Corten



HIN
Impero nero
Black Imper



HN
Nero
Black



HPI
Pietra
Stone



HS
sabbia
Sand

Struttura / Frames

Legno / Wood



LE11
Frassino naturale
Ash



LE12
Frassino tinto noce
Ash stained walnut



LE16
Frassino tinto nero
Ash stained black

Table

Mojito

Varianti / Versions



3941
Tavolo H 500 con base tonda Ø 550 in alluminio con piano in HPL o solid core.
Table H 500 with round base Ø 550 in aluminum with top in HPL or solid core.



3940
Tavolo H 750 con base tonda Ø 550 in alluminio con piano in HPL, laminato o nobilitato.
Table H 750 with round base Ø 550 in aluminum with top in, HPL, laminate or melamine.



3942
Tavolo H 1100 con base tonda Ø 550 in alluminio con piano in HPL, laminato o nobilitato.
Table H 1100 with round base Ø 550 in aluminum with top in HPL, laminate or melamine.

Dimensioni / Dimensions

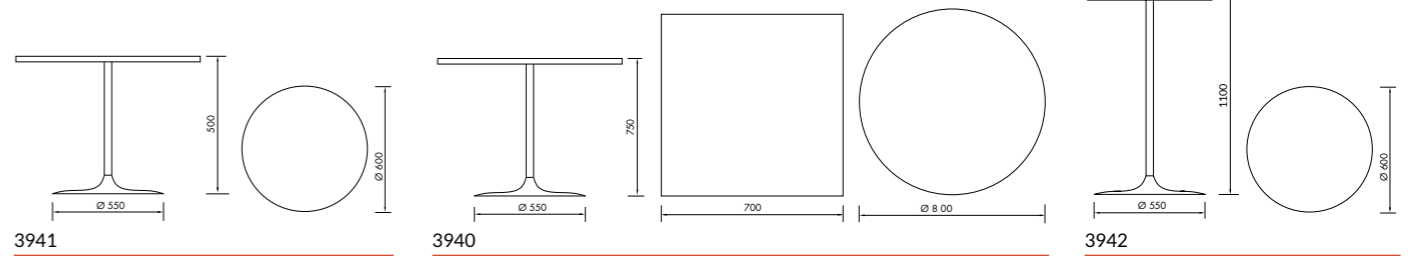

Colori piano / Top colors

Laminato nobilitato / Laminated melamine



B
Bianco
White



T*
Antracite
Anthracite

*Solo per laminato
Only laminated

Mdf laccato / Mdf laquered



LE05B
Laccato bianco
White laquered



LE18
Laccato sabbia
Sand laquered



LE19
Laccato antracite
Anthracite laquered

Solid core / Solid core



HB
Bianco
White

Hpl / Hpl



HB
Bianco
White



HN
Nero
Black



HS
Sabbia
Sand

Struttura / Frame

Alluminio / Aluminium



VB
Verniciato Bianco
White painted



VS
Verniciato sabbia
Sand painted



VT
Verniciato antracite
Anthracite painted

Paloalto

Varianti / Versions



3730H7

Tavolo H 750 con struttura in tubo d'acciaio e piano in frassino o nobilitato disponibile in tre dimensioni.
Table H 750 with steel tube structure and ash wood or melamine top, available in three sizes.



3730H1

Tavolo H 1100 con struttura in tubo d'acciaio e piano in frassino o nobilitato disponibile in tre dimensioni.
Table H 1100 with steel tube structure ash wood or melamine top, available in three sizes.

Dimensioni / Dimensions

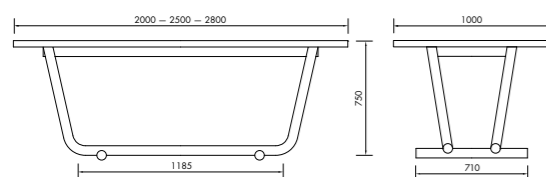

3730H7

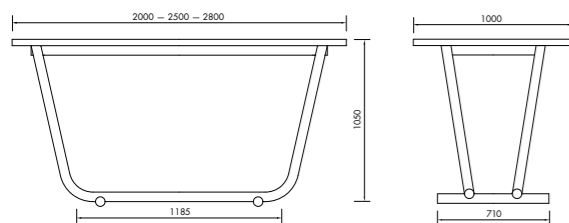

3730H1

Table

Colori piano / Top colors

Laminato nobilitato / Laminated melamine



B Bianco
White
C Grigio chiaro
Light grey
N* Nero
Black
T* Antracite
Anthracite

*Solo per laminato
Only laminated

Legno / Wood



LE11 Frassino naturale
Ash
LE12 Frassino tinto noce
Ash stained walnut
LE16 Frassino tinto nero
Ash stained black

Struttura / Frames

Metalli / Metals



VB Verniciato bianco
White painted
VT Verniciato antracite
Anthracite painted

Varianti / Versions



3660
Tavolo H 750 con base da 600 in acciaio verniciato.
Table H 750, 600 base in painted steel.



3666
Tavolo H 750 con base da 750 in acciaio verniciato.
Table H 750, 750 base in painted steel.



3665
Tavolo H 750 con 2 basi da 600 in acciaio verniciato.
Table H 750, n.2 600 bases in painted steel.



3662
Tavolo H 1100 con base da 600 in acciaio verniciato.
Table H 1100, 600 base in painted steel.



3661
Tavolo H 450 con base da 600 in acciaio verniciato.
Table H 450, 600 base in painted steel.

Dimensioni / Dimensions

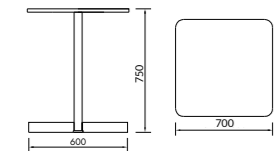

3660

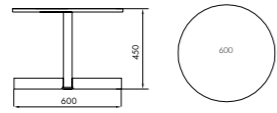

3661

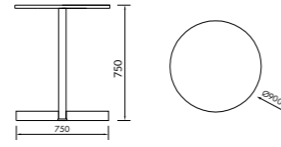

3666

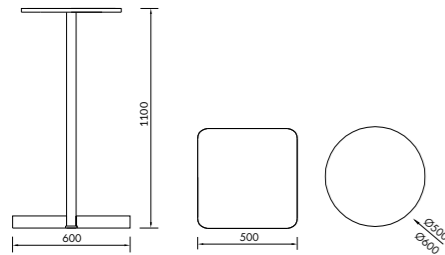

3662

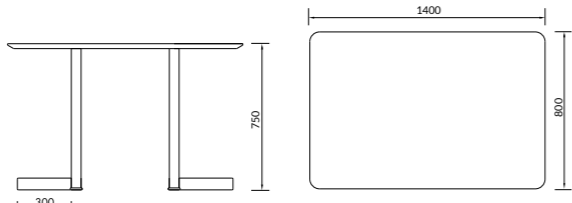

3665

Colori piano / Top colors

Laminato nobilitato / Laminated melamine



B Bianco White
C Grigio chiaro Light grey
N* Nero Black
T* Antracite Anthracite

Mdf laccato / Mdf laquered



LE05B Laccato bianco White laquered
LE18 Laccato sabbia Sand laquered
LE19 Laccato antracite Anthracite Laquered

Hpl / Hpl



HB Bianco White
HN Nero Black
HS Sabbia Sand
HB Bianco White

Solid core / Solid core

*Solo per laminato
Only laminated

Struttura / Frame

Metalli / Metals



VA Verniciato Alluminio Aluminium painted
VB Verniciato bianco White painted
VNO Verniciato nero Black painted
VS Verniciato sabbia Sand painted
VT Verniciato antracite Anthracite painted

Varianti / Versions



3790
Tavolo allungabile mm 1600+500+500x900 con struttura in legno di frassino e guide in alluminio verniciato, piano in stratificato sp.20.
Extendable table mm 1600+500+500x900 with ash wood frame and aluminium sliding guides, stratified top th 20.



Dimensioni / Dimensions

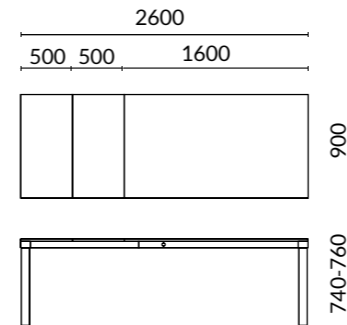

3790

Colori piano / Top colors

Legni / Woods



RAN Rovere Asburgo Naturale Natural Habsburg durmast oak
RCA Rovere Carbone Carchoal Coal durmast oak
RCN Rovere Canaletto Naturale Natural Canaletto Durmast oak

Struttura / Frames

Legni / Woods



LE11 Frassino naturale Natural ash wood
LE12 Frassino noce Walnut ash wood
LE16 Frassino nero Black ash wood

Guide / Guide

Alluminio / Aluminium



VR2 Verniciato Rosso Opaco Red matt painted
VNO Verniciato Nero Opaco Painted Black

Fascia anteriore / Front band

Legni / Woods



LE27 Frassino Tinto Rosso Red stained ash
LE11 Frassino naturale Natural ash wood
LE12 Frassino noce Walnut ash wood
LE16 Frassino nero Black ash wood

Varianti / Versions



378109090
Tavolo fisso mm 900x900 con telaio in alluminio e piano in HPL sp. 10 o laminato sp. 20.
Fixed table mm 900x900 with aluminium frame and HPL top th 10 or laminate top th 20.



378112090
Tavolo fisso mm 1200x900 con telaio in alluminio e piano in HPL sp. 10 o laminato sp.20
Fixed table mm 1200x900 with aluminium frame and HPL top th 10 or laminate top th 20.



378125090
Tavolo fisso mm 2500x900 con telaio in alluminio e piano in HPL sp. 10 o laminato sp.20.
Fixed table mm 2500x900 with aluminium frame and HPL top th 10 or laminate top th 20.

Dimensioni / Dimensions

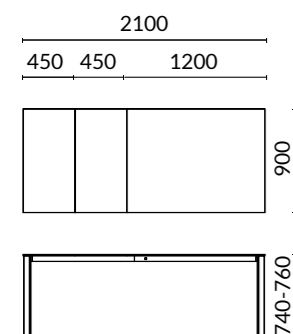

378109090

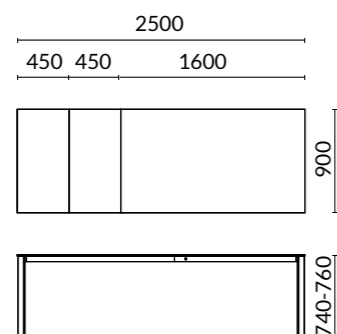

378016090

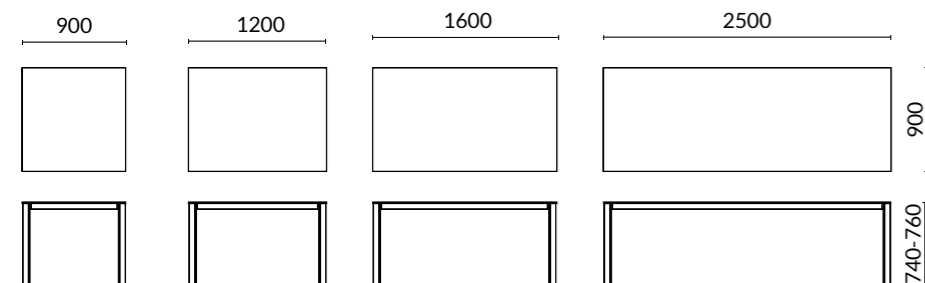

37819090

378112090

378116090

378125090

Struttura / Frames

Metalli / Metals

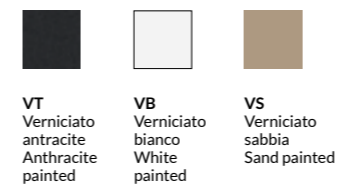

VT
Verniciato antracite
Anthraccite painted

VB
Verniciato bianco
White painted

VS
Verniciato sabbia
Sand painted

Colori piano / Top colors

HPL / Solid core

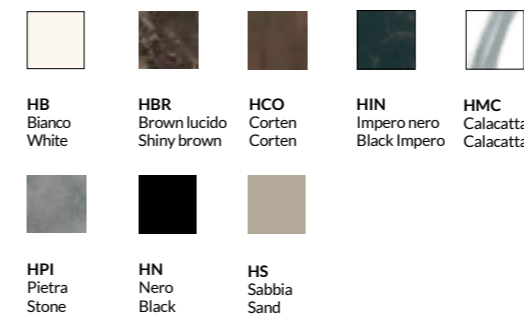

HB
Bianco
White

HBR
Brown lucido
Shiny brown

HCO
Corten
Corten

HIN
Impero nero
Black Impero

HMC
Calacatta
Calacatta

HPI
Pietra
Stone

HN
Nero
Black

HS
Sabbia
Sand

Laminato / Laminated

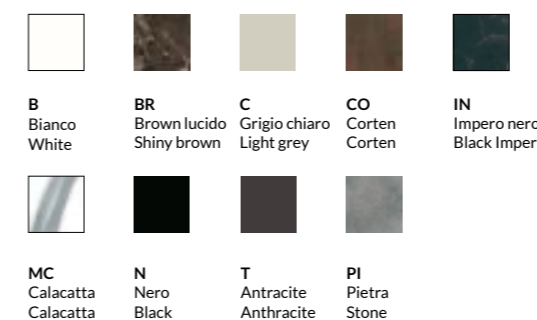

B
Bianco
White

BR
Brown lucido
Shiny brown

C
Grigio chiaro
Light grey

CO
Corten
Corten

IN
Impero nero
Black Impero

MC
Calacatta
Calacatta

N
Nero
Black

T
Antracite
Anthracite

PI
Pietra
Stone

Scala fixed table

Varianti / Versions



3770T12
Tavolo tondo con struttura in acciaio verniciato H 728/738 con piano in hpl/laminato Ø 1190.
Round table with painted steel frame H 728/738 with hpl/laminated Ø 1190 top.



3770T14
Tavolo tondo con struttura in acciaio verniciato H 728/738 con piano in hpl/laminato Ø 1390.
Round table with painted steel frame H 728/738 with hpl/laminated Ø 1390 top.



3770O17
Tavolo ovale con struttura in acciaio verniciato H 728/738 e piano in hpl/laminato 1700x1150.
Oval table with painted steel frame H 728/738 with hpl/laminated 1700x1150 top.



3770O21
Tavolo ovale con struttura in acciaio verniciato H 728/738 e piano in hpl/laminato 2100x1100.
Oval table with painted steel frame H 728/738 with hpl/laminated 2100x1100 top.

Dimensioni / Dimensions

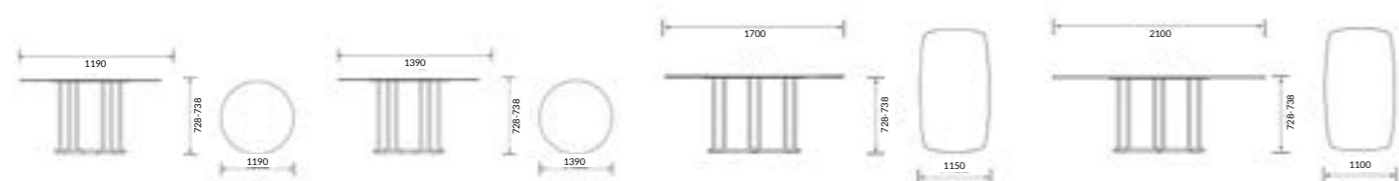

3770T12

3770T14

3770O17

3770O21

Colori piano / Top colors

Hpl / Hpl



HB Bianco White	HBR Brown lucido Shiny brown	HCO Corten Corten	HIN Impero Nero Black Imper	HMC Calacatta Calacatta	HN Nero Black	HPI Pietra Stone	HS Sabbia Sand
------------------------------	---	--------------------------------	--	--------------------------------------	----------------------------	-------------------------------	-----------------------------

Laminato / Laminated



B Bianco White	BR Brown lucido Shiny brown	C Grigio chiaro Light grey	CO Corten Corten	IN Impero Nero Black Imper	MC Calacatta Calacatta	N Nero Black	PI Pietra Stone	T Antracite Anthracite
-----------------------------	--	---	-------------------------------	---	-------------------------------------	---------------------------	------------------------------	-------------------------------------

Struttura / Frames

Metalli per indoor / Metals for indoor



VAG Bronzo Bronze	VNO Verniciato nero Black polished
--------------------------------	---

Metalli per outdoor / Metals for outdoor



VB Verniciato bianco White painted	VS Verniciato sabbia Sand painted	VT Verniciato antracite Anthracite painted
---	--	---

Scala indoor extending table

Varianti / Versions



3771T12
Tavolo allungabile con struttura in acciaio verniciato H 760/770 e piano in hpl/laminato Ø 1190+400. Prolunga in laminato.
Extendable table with painted steel frame H 760/770 and hpl/laminated top Ø 1190+400. Extendable part in laminated.

Dimensioni / Dimensions

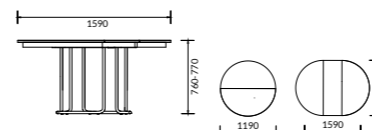

3771T12

Colori piano / Top colors

Hpl / Hpl



HB Bianco White	HBR Brown lucido Shiny brown	HCO Corten Corten	HIN Impero Nero Black Imper	HMC Calacatta Calacatta	HN Nero Black	HPI Pietra Stone	HS Sabbia Sand
------------------------------	---	--------------------------------	--	--------------------------------------	----------------------------	-------------------------------	-----------------------------

Laminato / Laminated



B Bianco White	BR Brown lucido Shiny brown	C Grigio chiaro Light grey	CO Corten Corten	IN Impero Nero Black Imper	MC Calacatta Calacatta	N Nero Black	PI Pietra Stone	T Antracite Anthracite
-----------------------------	--	---	-------------------------------	---	-------------------------------------	---------------------------	------------------------------	-------------------------------------

Struttura / Frames

Metalli per indoor / Metals for indoor



VAG Bronzo Bronze	VNO Verniciato nero Black polished
--------------------------------	---

Scala indoor Coffee table

Varianti / Versions



3760H4

Tavolino con struttura in acciaio verniciato e piano in MDF sp. 25 laccato Ø 400.
Coffee table painted steel frame with MDF laquered top th 25 Ø400.



3760H5

Tavolino con struttura in acciaio verniciato e piano in MDF sp. 25 laccato Ø 500.
Coffee table painted steel frame with MDF laquered top th 25 Ø 500.



3760H6

Tavolino con struttura in acciaio verniciato e piano in MDF sp. 25 laccato Ø 360.
Coffee table painted steel frame with MDF laquered top th 25 Ø 360.

Dimensioni / Dimensions

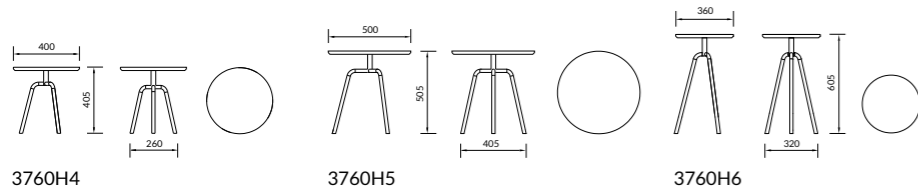

3760H4

3760H5

3760H6

Colori Piano / Top colors

Mdf / Mdf



LE05B
Laccato bianco freddo
Cold white laquered

LE07
Laccato nero
Black laquered

LE25
Laccato grigio ghiaia
Pebble grey laquered

LE26
Laccato rosso ossido
Red oxyde laquered

Struttura / Frames

Metalli / Metals



VAG
Bronzo
Bronze

VNO
Verniciato nero
Black polished

Scala Coffee table

Varianti / Versions



3761T

Tavolino con struttura in acciaio verniciato H 345/367 mm con piano Ø 750 in hpl/mdf.
Coffee table with painted steel frame H 345/367 mm with Ø 750 hpl/mdf top.



3761O

Tavolino con struttura in acciaio verniciato H 345/367 mm con piano ovale da 990/1000x690 in hpl/mdf.
Coffee table with painted steel frame H 345/367 mm with 990/1000x690 hpl/mdf oval top.



3762T

Tavolino in acciaio verniciato H 490/512 mm con piano Ø 390/400 in hpl/mdf.
Coffee table with painted steel frame H 490/512 mm with Ø 390/400 hpl/mdf top.

Dimensioni / Dimensions

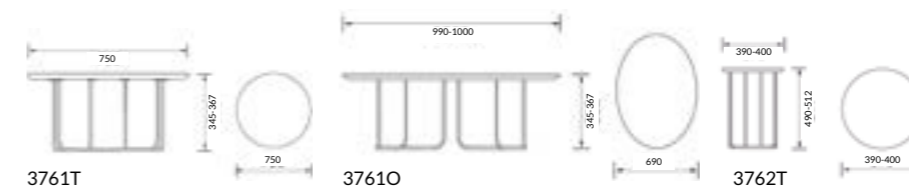

3761T

3761O

3762T

Colori piano / Top colors

Mdf / Mdf



LE05B
Laccato bianco freddo
Cold white laquered

LE07
Laccato nero
Black laquered

LE25
Laccato grigio ghiaia
Pebble grey laquered

LE26
Laccato rosso ossido
Lacquered oxide red

Hpl / Hpl

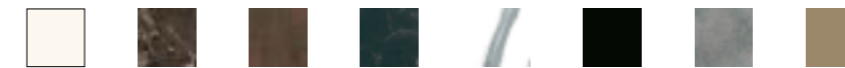

HB
Bianco
White

HBR
Brown lucido
Shiny brown

HCO
Corten
Corten

HIN
Impero Nero
Black Imper

HMC
Calacatta
Calacatta

HN
Nero
Black

HPI
Pietra
Stone

HS
Sabbia
Sand

Struttura / Frames

Metalli per indoor / Metals for indoor



VAG
Bronzo
Bronze

VNO
Verniciato nero
Black polished

Metalli per outdoor / Metals for outdoor



VB
Verniciato bianco
White painted

VS
Verniciato sabbia
Sand painted

VT
Verniciato antracite
Anthracite painted

Varianti / Versions



3090
Tavolo H 730 in polietilene colorato con base in cemento.
Table H 730 in colored polyethylene with concrete base.



3090
Tavolo H 1040 in polietilene colorato con base in cemento.
Table H 1040 in colored polyethylene with concrete base.

Dimensioni / Dimensions

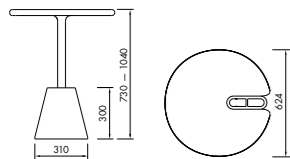

3090

Piano / Top

Polietilene / Polyethylene



A Antracite
B Bianco
RC Rosso ciliegia
VB Verde bosco

Varianti / Versions



3712H7
Tavolo H 750 in faggio con piano rettangolare in nobilitato sp. 25 o in HPL sp. 10.
Rectangular table H 750 in beech-wood with melamine top th 25 or HPL top th 10.



3710H7 - 3711H7
Tavolo H 750 in faggio con piano quadrato o tondo in nobilitato sp. 25 o in HPL sp. 10.
Square or round table H 750 in beech-wood with melamine top th 25 or HPL top th 10.



3710H1
Tavolo H 1100 in faggio con piano quadrato o tondo in nobilitato sp. 25 o in HPL sp. 10.
Square or round table H 1100 in beech-wood with melamine top th 25 or HPL top th 10.

Dimensioni / Dimensions

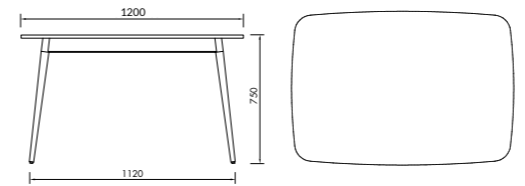

3712H7

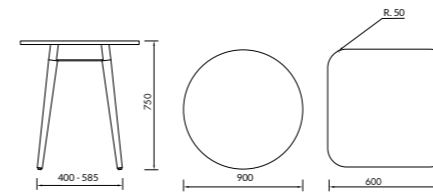

3710H7 - 3711H7

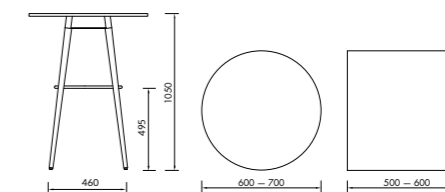

3710H1

Colori piano / Top colors

Laminato nobilitato / Laminated melamine



B Bianco
C Grigio chiaro
N* Nero
T* Antracite

*Solo per laminato
Only laminated

Hpl / Hpl



HB Bianco
HN Nero

Struttura / Frame

Legno / Wood



LE22 Faggio Naturale
LE23 Faggio Noce
LE24 Faggio nero

Woodbridge

Varianti / Versions



3720H7

Tavolo in frassino H 750 con piano in multistrato dai bordi massellati sp. 40.
Ash-wood table H 750, with multilayer top with solid wood edge th 40.



3720H1

Tavolo in frassino H 1050 con piano in multistrato dai bordi massellati sp. 40.
Ash-wood table H 1050, with multilayer top with solid wood edges th 40.

Dimensioni / Dimensions

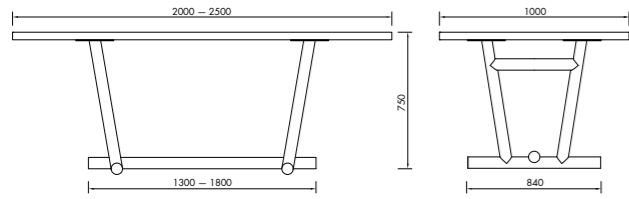

3720H7

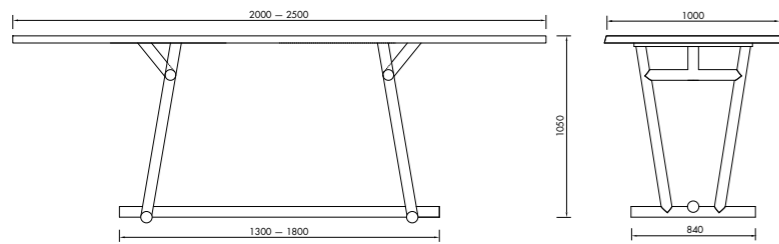

3720H1

Colori piano / Top Colors

Legno / Wood



LE11 Frassino naturale Ash
LE12 Frassino tinto noce Ash stained walnut
LE16 Frassino tinto nero Ash stained black

Struttura / Frames

Legno / Wood



LE11 Frassino naturale Ash
LE12 Frassino tinto noce Ash stained walnut
LE16 Frassino tinto nero Ash stained black

Table

X Table

Varianti / Versions



3670

Tavolino H 455 in frassino o acciaio verniciato con piano in MDF laccato opaco o frassino verniciato.
Coffee table H 455 in ash-wood or painted steel with top in matt lacquered MDF or stained ash-wood.



3671

Tavolino H 295 in frassino o acciaio verniciato con piano in MDF laccato opaco o frassino verniciato.
Coffee table H 295 in ash-wood or painted steel with top in matt lacquered MDF or stained ash-wood.



3672

Tavolo H 740 in acciaio verniciato con piano in MDF laccato opaco o frassino verniciato o nobilitato.
Table H 740 in painted steel with top in matt lacquered MDF or painted ash-wood or melamine.

Dimensioni / Dimensions

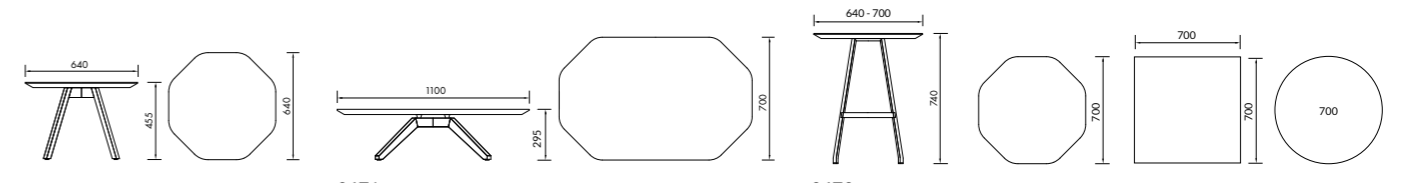

3670

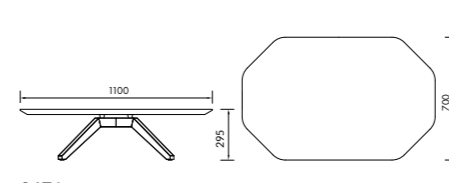

3671

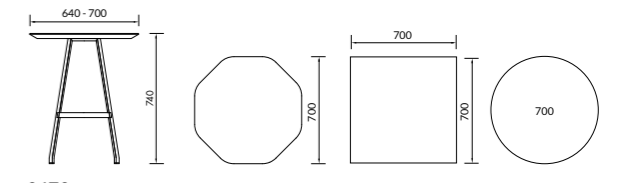

3672

Colori piano / Top colors

Mdf / Mdf



LE05B Laccato bianco White laquered
LE18 Laccato sabbia Sand laquered
LE19 Laccato antracite Anthracite laquered

Laminato nobilitato / Laminated melamine



B Bianco White
C Grigio chiaro Light grey
N* Nero Black
T* Antracite Anthracite

*Solo per laminato
Only laminated

Legno / Wood



LE11 Frassino naturale Ash
LE12 Frassino tinto noce Ash stained walnut
LE16 Frassino tinto nero Ash stained black

Struttura / Frames

Metalli / Metals



VB Verniciato bianco White painted
VS Verniciato sabbia Sand painted
VT Verniciato antracite Anthracite painted

Legno / Wood



LE11 Frassino naturale Ash
LE12 Frassino color noce Ash stained walnut
LE16 Frassino tinto nero Ash stained black

Pouf
Sgabelli
Pouf
Stool

Varianti / Versions



4051

Sgabello H 450 in polietilene colorato.
Coloured polyethylene low stool H 450.



4050

Sgabello H 750 in polietilene colorato.
Coloured polyethylene stool H 750.

Dimensioni / Dimensions



4051

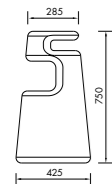

4050

Seduta / Seat

Polietilene / Polyethylene



A Antracite
Anthracite

B Bianco
White

O Arancio
Orange

RC Rosso ciliegia
Cherry red

S Sabbia
Sand

Varianti / Versions



4030

Sgabello impilabile con base cromata o verniciata e scocca in multistrato.
Stackable stool with chromed or painted base and beech plywood shell.



4030

Sgabello impilabile con base cromata o verniciata e scocca in multistrato di faggio in versione imbottita.
Stackable stool with chromed or painted base and beech plywood shell, in the upholstered version.



CS403

Cuscino.
Cushion.

Dimensioni / Dimensions

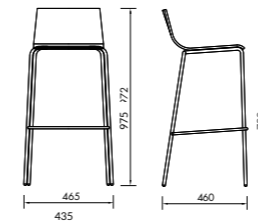

4030

Seduta / Seat

Legno / Wood



LE01 Rovere
Oak

LE03 Wengè
Wengè

Struttura / Frames

Metalli / Metals



CR Cromato
Chromed

VNO Verniciato nero
Black painted

Rivestimenti / Materials

CAT A Spalmato - Touch
CAT B Origami
CAT B1 Stone Velvet - Jojo
CAT C Capri
CAT D Plush
CAT D1 Velluto Luna
CAT E Hero
CAT PE Pelle Miami

Estrosa

Varianti / Versions



4020 / 4021

Sgabello con struttura a slitta in acciaio e sedile in alluminio estruso e anodizzato.
Stool with sled steel structure and seat in extruded and anodized aluminium.

Dimensioni / Dimensions

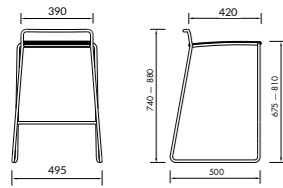

4020 / 4021

Seduta / Seat

Alluminio / Aluminium



AU01
Nero
Black

AU02
Grigio
Grey

Struttura / Frames

Metalli / Metals



CR
Cromato
Chromed

VA
Verniciato
alluminio
Aluminium
painted

VNO
Verniciato
nero
Black painted

Stool



RAPPORTO DI PROVA N° 125607 EN 1728:2000

Jo

Varianti / Versions



4070

Sgabello in polietilene colorato.
Coloured polyethylene stool.



4071

Sgabello in polietilene colorato con sedile e schienale imbottiti.
Coloured polyethylene stool with seat and back upholstered.



4072

Sgabello in polietilene colorato con sedile imbottito.
Colored polyethylene stool with seat upholstered.

Dimensioni / Dimensions

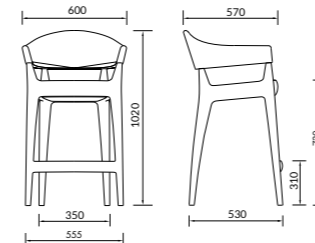

4070 / 4071 / 4072

Seduta / Seat

Polietilene / Polyethylene



A
Antracite
Anthracite

B
Bianco
White

GA
Giallo ambra
Amber yellow

RC
Rosso ciliegia
Cherry red

S
Sabbia
Sand

VB
Verde bosco
Dark green

Rivestimenti / Materials

CAT A Spalmato - Touch - Roccia - King L Kat

Stool

OMOLOGAZIONE CL1IM

Minnie

Varianti / Versions



4140 / 4141

Sgabello in due altezze in frassino verniciato con poggia piedi in acciaio.
Painted ash wood stool available in two heights with steel footrest.

4142 / 4143

Sgabello in due altezze in frassino verniciato con poggia piedi in acciaio e sedile imbottito.
Painted ash wood stool available in two heights with steel footrest and upholstered seat.

Dimensioni / Dimensions

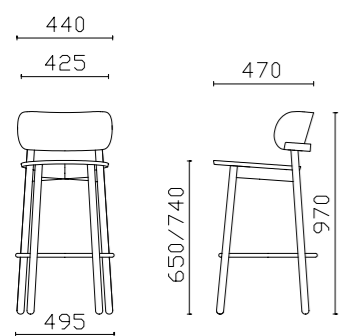

4140 / 4141

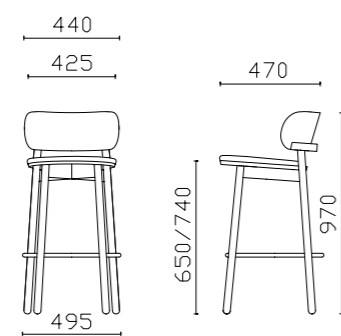

4142 / 4143

Seduta / Seat

Legni / Wood



LE11 Frassino naturale / Natural ash wood
LE12 Frassino noce / Walnut ash wood
LE16 Frassino nero / Black ash wood
LE28 Frassino salvia / Sage wood

Poggia piedi/

Metalli / Metals



CRS Cromo satinato / Satin chrome
NS Nikel nero satinato / Satin black nickel

Cuscino/ Cushion

CAT A Touch - King L kat - Roccia
CAT D1 Velluto Luna

358

Stool

Nonò

Varianti / Versions



4040

Seduta a 3 gambe in polipropilene colorato.
Seat with 3 legs in colored polypropylene.

Dimensioni / Dimensions

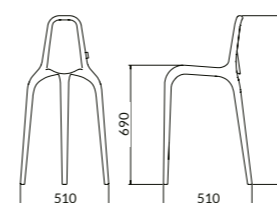

4040

Seduta / Seat

Polietilene / Polyethylene



A Antracite / Anthracite
B Bianco / White
L Lime / Lime

Stool

CATAS

RAPPORTO DI PROVA N° 125605 EN 1728:2000, EN 1022:2005
RAPPORTO DI PROVA N° 125606 AINSI-BIFMA X5.1-2002/16



GOOD DESIGN

358

359

Pepper

Coffee table, pouf and stools

Scala

Varianti / Versions



3680

Tavolino H 450 in polietilene colorato.
Coloured polyethylene table H 450.



3681

Tavolino H 450 in polietilene con luce.
Polyethylene table H 450 with light.



3682

Sgabello H 450 rivestito.
Upholstered stool H 450.

Dimensioni / Dimensions



3680 - 3681 - 3682

Scocca / Shell

Polietilene / Polyethylene



A
Antracite
Anthracite

B
Bianco
White

VX
Viola
bordeaux
Violet
bordeaux

GA
Giallo ambra
Amber yellow



RC
Rosso ciliegia
Cherry red

S
Sabbia
Sand

VB
Verde bosco
Dark green

Colori cavi / Cablecolor

Per interno / Indoor: cotone rosso - trasparente / red cotton - transparent
Per esterno / Outdoor: nero IP44 / black IP44

Rivestimenti / Materials

CAT A Spalmato - Touch - King L Kat

Varianti / Versions



4130

Sgabello imbottito con struttura in acciaio verniciato, disponibile in due altezze.
Upholstered stool with painted steel structure, available in two heights.

Dimensioni / Dimensions

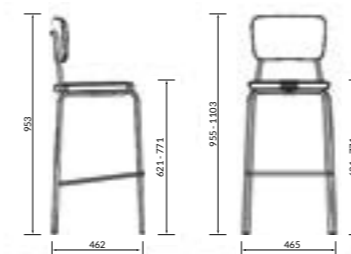

4130

Struttura / Frames

Metalli / Metals



VAG
Bronzo
Bronze

VNO
Verniciato nero
Black polished

Rivestimenti / Materials

CAT A Spalmato - Touch
CAT B Origami
CAT B1 Stone Velvet - Jojo
CAT C Capri
CAT D Plush
CAT D1 Velluto Luna
CAT E Hero
CAT PE Pelle Miami
CAT PE1 Pelle Lotus

Varianti / Versions



4060
Sgabello 4 gambe tubo tondo con scocca in polipropilene h 750 (x four)
4 legs stool round tube with polypropylene shell h 750 (x four)



4061 - 4064
Sgabello 4 gambe tubo rettangolare con scocca in polipropilene H 750/650 (X Spider).
4-legs rectangular tube stool with polypropylene shell H 750/650 (X Spider).



4062 - 4065
Sgabello 4 gambe in frassino con scocca in polipropilene H 760/650 (X Wood).
4-legs ash wood frame stool with polypropylene shell H 760/650 (X Wood).

Dimensioni / Dimensions



4060

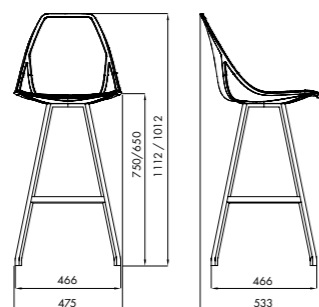

4061 - 4064

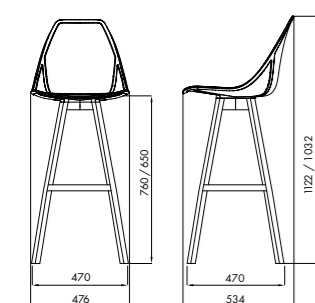

4062 - 4065

Varianti / Versions



CS108T
Cuscino intero (x soft).
Shell cushion (x soft).



CS108S
Cuscino sedile (x soft).
Seat cushion (x soft).

Scocca / Shell

Polipropilene / Polypropylene

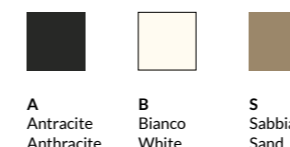

A Antracite
Anthracite
B Bianco
White
S Sabbia
Sand

Struttura / Frames

Metalli / Metals



CR* Cromato
Chromed
VA Verniciato alluminio
Aluminium painted
VB Verniciato bianco
White painted
VS Verniciato sabbia
Sand painted
VT Verniciato antracite
Anthracite painted

*Solo per cod. 4060
Only for 4060 code

Legno / Wood



LE11 Frassino naturale
Ash
LE12 Frassino tinto noce
Ash stained walnut
LE16 Frassino tinto nero
Ash stained black

Rivestimenti / Materials

CAT A Spalmato - Touch - Roccia - King L Kat
CAT B1 Stone Velvet - Jojo
CAT D1 Velluto Luna

Finiture *Finishes*

Alma

Polipropilene e polietilene / Polypropylene and polyethylene



A Antracite / Anthracite
 B Bianco / White
 BS Blu smeraldo / Emerald blue
 BV Blu viola / Violet blue
 BX Viola bordeaux / Violet bordeaux
 C Cipria / Powder pink
 G Grigio / Grey



GA Giallo ambra / Amber yellow
 L Lime / Lime
 N Nero / Black
 O Arancio / Orange
 RC Rosso ciliegia / Cherry red
 R2 Rosso mattone / Brick red
 S Sabbia / Sand



VB Verde bosco / Dark green

Policarbonato / Polycarbonate

Si sconsiglia l'esposizione alla salsedine.
 /Not recommended exposure to saltiness.

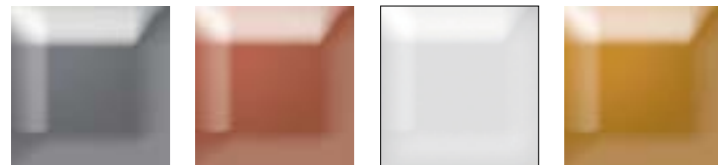

F Fumè
 RT Rosso / Red
 T Trasparente / Transparent
 YT Giallo / Yellow

Nylon

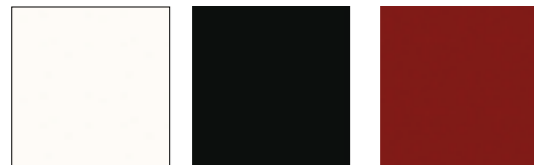

B Bianco lucido / White polished
 N Nero lucido / Black polished
 RP Rosso pompeiano lucido / Pompeian red polished

Finiture / Finishes

Finiture metalli e alluminio verniciato / Metal and painted aluminium finishes

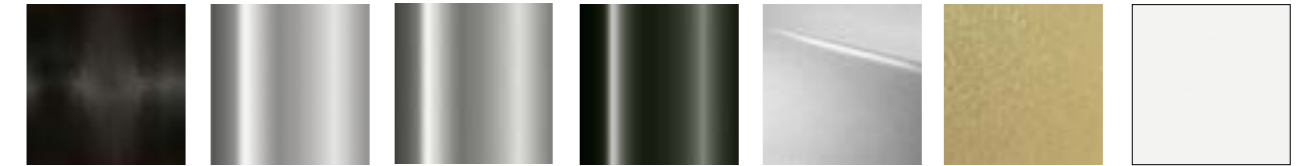

CE Calamina / Calamine
 CR Cromato / Chromed
 CRS Cromo satinato / Satin chrome
 NS Nikel nero satinato / Satin black nikel
 VA Verniciato alluminio goffratino / Aluminium painted
 VAG Verniciato bronzo / Bronze painted
 VB Verniciato bianco / White painted



VB1 Verniciato bianco lucido / White polished painted
 VEB Verniciato verde bosco / Dark green painted
 VN Verniciato nero lucido / Black polished painted
 VNO Verniciato nero goffratino / Black matt painted
 VR Verniciato rosso opaco / Red painted
 VR2 Verniciato rosso opaco / Red matt painted
 VS Verniciato sabbia opaco / Sand painted



VT Verniciato antracite / Anthracite painted

Alluminio / Aluminium

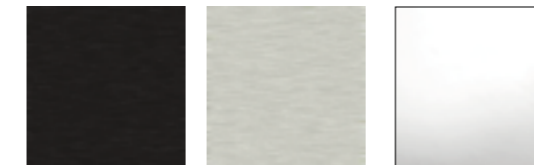

AU01 Nero / Black
 AU02 Grigio / Grey
 AU09 Lucido / Polished

Legni e MDF / Wood and MDF



LE01 Rovere / Oak
 LE03 Wengè / Wengè
 LE05B Laccato bianco freddo / Cold white laquered
 LE07 Laccato nero / Black laquered
 LE11 Frassino naturale / Ash-wood
 LE12 Frassino color noce / Ash-wood stained walnut
 LE16 Frassino tinto nero / Ash-wood stained black



LE18 Laccato sabbia / Sand laquered
 LE19 Laccato antracite / Anthracite laquered
 LE22 Faggio naturale / Natural beech-wood
 LE23 Faggio noce / Walnut beech-wood
 LE24 Faggio nero / Black beech-wood
 LE25 Laccato grigio ghiaia / Pebble grey laquered
 LE26 Laccato rosso ossido / Red oxyde laquered



LE27 Frassino tinto rosso / Red stained ash
 LE28 Frassino tinto salvia / Sage stained ash
 RAN Rovere Asburgo Naturale / Natural Habsburg durmast oak
 RCA Rovere Carbone / Charcoal Coal Durmast oak
 RCN Rovere Canaletto Naturale / Natural Canaletto Durmast oak

HPL and Solid Core

**solo HPL / only HPL

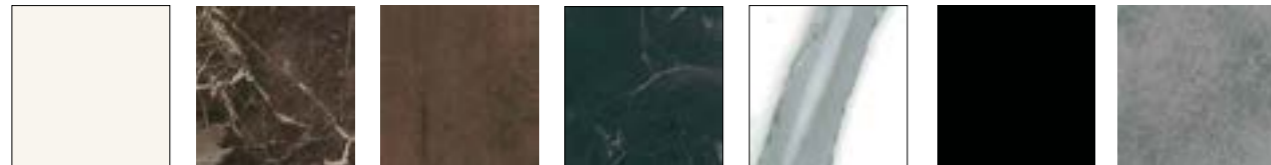

HB Bianco / White
 HBR** Brown lucido / Shiny brown
 HCO** Corten / Corten
 HIN** Impero nero / Black Imper
 HMC** Calacatta / Calacatta
 HN** Nero / Black
 HPI** Pietra / Stone



HS** Sabbia / Sand

Marmo e pietra / Marble and stone

La tonalità delle superfici in pietra può variare su ognuno dei pezzi prodotti.
 /The nuance of the surface in natural stone change on every piece produced.



MNM Nero marquina / Black marquina
 MCL Marmo Carrara lucido / Carrara marble polished

Laminato e nobilitato / Laminated and melamine

*solo laminato / only laminate
 **solo nobilitato / only melamine



B Bianco / White
 BR* Brown lucido / Shiny brown
 C Grigio chiaro / Light grey
 CO* Corten / Corten
 IN* Impero nero / Black Imper
 LB* Laminato folding bianco cemento / Cement white laminated
 LN* Laminato folding noce / Walnut laminated

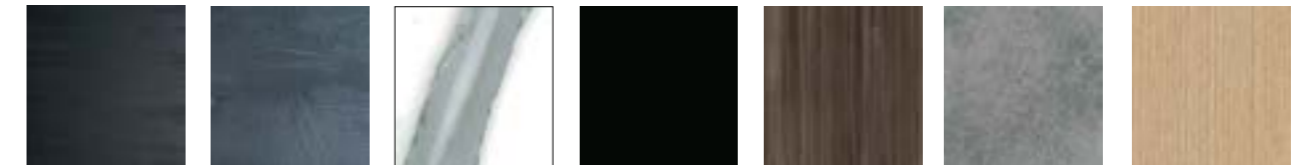

LNC* Laminato folding nero carbone / Laminated black coal
 LP* Laminato folding pietra / Stone laminated
 MC* Calacatta / Calacatta
 N* Nero / Black
 OG** Olmo grigio scuro / Dark grey olmo
 PI* Pietra / Stone
 R Rovere / Oak



RG Rovere grigio / Grey oak
 T* Antracite / Anthracite
 W Wengè / Wengè

Rivestimenti *Materials*

Alma

Corde / Ropes



TR001 TR002 TR003

Tappeti / Rugs



RA01 RA02 LA01 LA02 LA03

Spalmato — categoria / category A

 Antifiamma / Flame retardant



TE08 TE11 TE67 TE69 TE70 TE71 TE72



TE73 TE77 TE78 TE79 TE80

Rivestimenti / Materials

Touch — categoria / category A

 Antifiamma / Flame retardant



ABFP0108 ABFP015796 ABFP016783 ABFP015800 ABFP015804 ABFP0120 ABFP0115



ABFP0114 ABFP0125 ABFP0101 ABFP016747 ABFP016777 ABFP016791 ABFP0116

Roccia — categoria / category A

 Antifiamma / Flame retardant

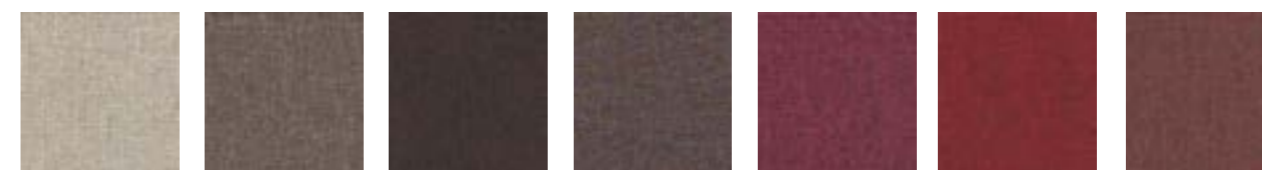

FDVRC1502 FDVRC1504 FDVRC2504 FDVRC6508 FDVRC4505 FDVRC4504 FDVRC4502



FDVRC3506 FDVRC3502 FDVRC5504 FDVRC4501 FDVRC6501 FDVRC7504 FDVRC7501



FDVRC6504 FDVRC8502 FDVRC8504

Alma

King L Kat — categoria / category A

 Antifiamma / Flame retardant



Origami — categoria / category B

 Antifiamma solo CAL 117 / Flame retardant only CAL 117



Rivestimenti / Materials

Stone Velvet — categoria / category B1

 Antifiamma solo CAL 117 / Flame retardant only CAL 117



Jojo — categoria / category B1



Alma

Capri — categoria / category C

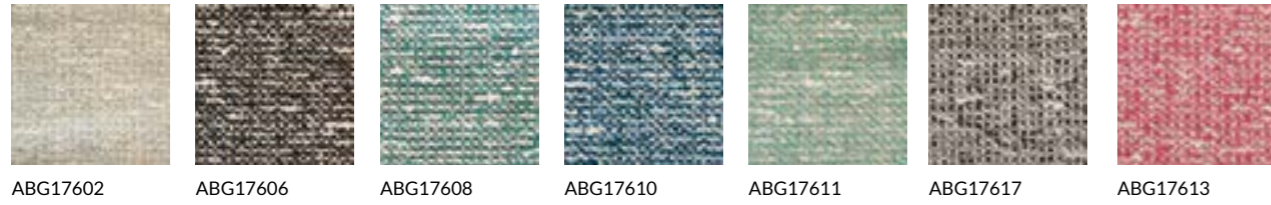

ABG17602 ABG17606 ABG17608 ABG17610 ABG17611 ABG17617 ABG17613

Fortezza — categoria / category C



PZAFO02 PZAFO661 PZAFO241 PZAFO691 PZAFO491

Antifiamma / Flame retardant
Utilizzo ambiente esterno / Outdoor use

Itaca — categoria / category C



GLAIT33 GLAIT35 GLAIT25

Antifiamma / Flame retardant
Utilizzo ambiente esterno / Outdoor use

Rivestimenti / Materials

Tropea — categoria / category D

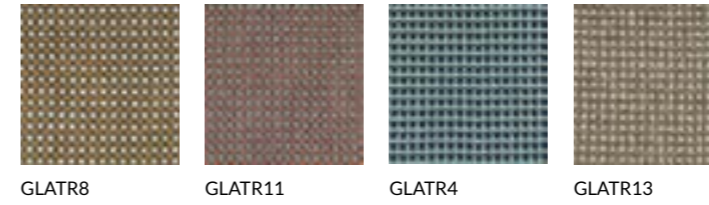

GLATR8 GLATR11 GLATR4 GLATR13

Antifiamma solo CAL 117 / Flame retardant only CAL 117
Utilizzo ambiente esterno / Outdoor use

Plush — categoria / category D



ERMPLA1900 ERMPLA1901 ERMPLA1902 ERMPLA1904 ERMPLA1905 ERMPLA1906 ERMPLA1908

Antifiamma solo CAL 117 / Flame retardant only CAL 117

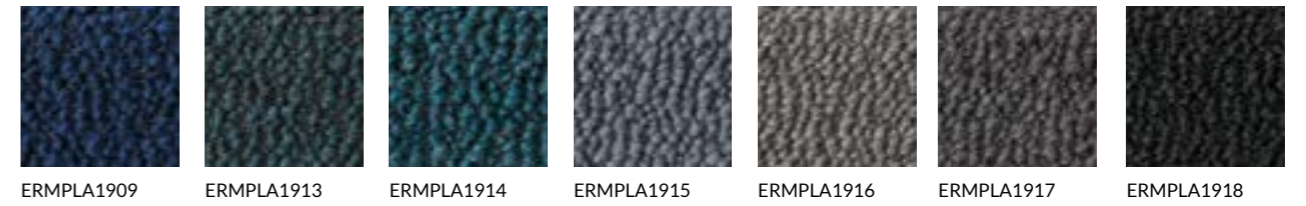

ERMPLA1909 ERMPLA1913 ERMPLA1914 ERMPLA1915 ERMPLA1916 ERMPLA1917 ERMPLA1918

Velluto Luna — categoria / category D1



TE188 TE191 TE192 TE199 TE202 TE205 TE206

Antifiamma / Flame retardant



TE207 TE208 TE209 TE210 TE214 TE216 TE217





TE218 TE219 TE220 TE222 TE223 TE225 TE226

Alma

Salina — categoria / category E



GLASA612 GLASA613 GLASA608 GLASA602

 Antifiamma / Flame retardant
 Utilizzo ambiente esterno / Outdoor use

Hero — categoria / category E



KVHR181 KVHR151 KVHR751 KVHR931 KVHR101

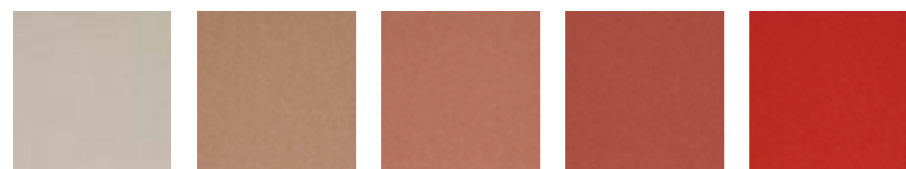

KVHR211 KVHR311 KVHR511 KVHR541 KVHR551

 Antifiamma / Flame retardant

Rivestimenti / Materials

Pelle Miami — categoria / category PE

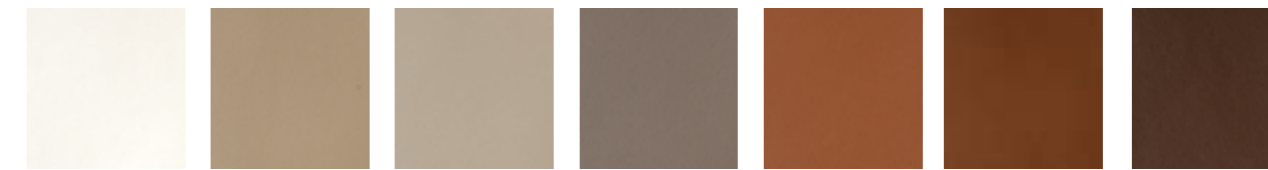

ICAMI1000 ICAMI1005 ICAMI1011 ICAMI1013 ICAMI2001 ICAMI2006 ICAMI2007

 Antifiamma / Flame retardant



ICAMI2010 ICAMI4001 ICAMI4100 ICAMI4020 ICAMI4011 ICAMI5020 ICAMI5010



ICAMI8004 ICAMI9000

Pelle Lotus — categoria / category PE1

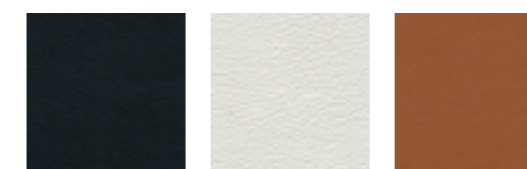

ICALOBAC ICALOSNOW ICALOCOGN

 Antifiamma / Flame retardant

Cuoio — categoria / category CU



CU02 CU05 CU08 CU09

I colori, le finiture ed i materiali dei prodotti
in questo catalogo potrebbero non essere
sempre disponibili e/o cambiare così
come i disegni tecnici che sono inseriti
al solo fine esplicativo.

*Colours, finishes, and materials listed
in this catalogue may not always be available
and/or change; the same for the technical
drawings, which are mere examples
and may change.*

ALMA®

Via P. Mazzolari, 34 - Z.I.
25050 Passirano (BS) - Italy
tel. +39 030.6857523
+39 030.6549908
fax +39 030.6577771
info@alma-design.it

alma-design.it

