

Design Mario Mazzer

VERSIONI E MATERIALI

Poltrona con gambe in frassino. Seduta in legno curvato, imbottita, rivestimenti da campionario. Carter posteriore a vista in varie tinte di frassino.

VERSIONS AND MATERIALS



Armchair with ash wood legs. Seat made of bent wood, padded, materials from sample book. Rear cover in various shades of ash wood.

VERSIONS ET MATÉRIAUX

Fauteuil avec pieds en bois de frêne. Assise en bois courbé, rembourré selon nuancier. Carter arrière à voir dans différentes nuances de frêne.

Scocca / Shell / Coque		Struttura / Frame / Structure			
Legno / Wood / Bois	Pg. XXII	Legno / Wood / Bois	Pg. XXII		
 LE11 Frassino naturale Ash Frêne naturel	 LE12 Frassino color noce Ash stained walnut Frêne noyer	 LE16 Frassino tinto nero Ash stained black Frêne timenté noir	 LE11 Frassino naturale Ash Frêne naturel	 LE12 Frassino color noce Ash stained walnut Frêne noyer	 LE16 Frassino tinto nero Ash stained black Frêne timenté noir

Rivestimenti / Materials / Revêtements													
Cat A	Pg. VI	Cat B	Pg. VIII	Cat C	Pg. IX	Cat D	Pg. X	Cat E	Pg. XI	Cat PE	Pg. XII	Cat PE 1	Pg. XIII
Spalmato 3% PU, 25% CO, 72% PVC		Stone Velvet 80% PES, 20% CO		Capri 16% VI, 47% CO, 8% LI, 14%PL,14%PC, 2%PA		Plush 38%CO, 25%PL, 19%PC,18%WV		Hero 96% WV, 4% PA		Pelle Miami 100% LEATHER/CAIR		Pelle Lotus 100% leather green tan / cuir avec tannage vert	
Touch 69% PVC, 20% PES, 10% CO, 1% PU		Origami 100% CO				Velluto luna 100% PL TREVIRA							
		Jojo 65% CO, 25% PV, 10% PL											

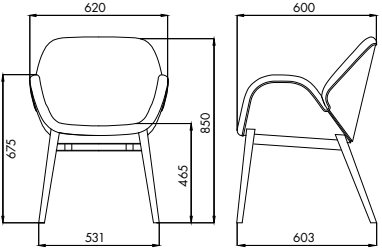
Varianti / Variants / Variantes							
Art.		Descrizione / Description / Description	 cm	M3	N.	Tot Kg Box	
2070		POLTRONCINA CON BASE E CARTER IN FRASSINO, IMBOTTITA Ash armchair with ash base and carter, upholstered Fauteuil en bois de frêne avec carter en bois de frêne, rembourré		64x62xh86	0,34	1	14